

ACE Automatic
Computerized
Oedometer

26-WF31E20

ACE EmS



**MANUALE DI ISTRUZIONI
INSTRUCTION MANUAL**

Index

1. INTRODUCTION	1
1.1 Icons appearing in the manual	4
1.2 Manual revision history	5
1.3 Symbols used	6
1.4 Intended use and improper use	7
1.5 Safety information	8
1.6 Environmental risks and disposal	13
1.7 CE declaration	14
2. DESCRIPTION	15
2.1 Connections	17
2.2 Identification plate	18
2.3 Technical specifications	19
3. INSTALLATION	21
3.1 Shipment	22
3.2 Unpacking and inspection	23
3.2.1 How to remove the equipment from the shipping crate	24
3.3 Positioning of the unit and space requirements	26
3.4 Electrical requirements	27
3.5 Installing the displacement transducer	28
3.6 Electrical connection	31
4. USE OF THE EQUIPMENT	33
4.1 Switching ON the equipment	34
4.2 MAIN MENU description	35
4.2.1 TEST RUN description	36
4.2.1.1 OEDOMETRIC CONSOLIDATION TEST	37
4.2.1.1.1 SPECIMEN DATA	38
4.2.1.1.2 CONSOLIDATION TABLE	38
4.2.1.1.3 CONSOLIDATION LOGGING MODE	40
4.2.1.2 UNCONFINED TEST	44
4.2.1.2.1 SPECIMEN DATA	45
4.2.1.2.2 TEST PARAMETERS	45
4.2.1.2.3 TEST LOGGING MODE	47
4.2.2 OPTIONS description	51
4.2.3 CALIBRATION description	56
4.2.3.1 Calibration screen	57
4.2.3.1.1 Transducer details	58
4.2.3.1.2 Machine controller in calibration	59

4.2.3.1.3	Reading.....	59
4.2.3.2	Manual Mode	60
4.2.4	INFO description.....	62
4.3	TITLE BAR description.....	63
4.4	KEYBOARD description.....	64
4.5	Carry out a test.....	65
4.5.1	Preparing the consolidation cell	65
4.5.2	Run the test.....	67
4.6	Turning OFF the ACE EmS units	74
4.7	Removal of the sample and cleaning	75
5. MAINTENANCE		77
5.1	Operator's preventive maintenance	78
5.2	Authorized service engineer maintenance actions	79
6. DIAGNOSTICS & TROUBLESHOOTING		80
6.1	By-passing overtravel microswitch.....	81

This instruction manual is an integral part of the machine and should be read before using the machine and be safely kept for future reference.

CONTROLS reserves all rights of this manual, no part or whole can be copied without the written permission of **CONTROLS**.

The proper use of this machine must be strictly adhered to, any other use must be considered as incorrect.

The manufacturer cannot be held responsible for damage caused by incorrect use of the machine.

The machine must not be tampered with for any reason. In case of tampering, the manufacturer declines any responsibility of functioning and safety of the machine.

This Manual is published by **CONTROLS**.

CONTROLS reserves the right to update its manuals without notification in order to correct possible typing errors, mistakes, updating of information and/or updating of programs and/or accessories.

Such changes will be inserted in the latest edition of the current manual.

This present manual in English is the original version. Printed in Italy

1. INTRODUCTION



NOTE:

The present manual is updated for the product it is sold with in order to grant an adequate reference in operating and maintaining the equipment.

The manual may not reflect changes to the product not impacting service operations.

The oedometer consolidation test is used to determine the rate and magnitude of consolidation of a soil specimen restrained laterally and subjected to a number of successive increments of vertical load.

ACE EmS is the fully automatic machine for performing oedometer tests. In this automatic model, the incremental loading is fully automatic in load (stress) or swelling (strain) modes, and offers a practical and accurate way to execute a test with reliable test results.

It features a closed loop PID control optimized for automatic test performance at the touch of a button, dead weights and air compressor are no more necessary.

ACE EmS (Automatic Computerized oEdometer) consists of a small and compact load frame housing Electromechanical Servoactuation system. In the standard configuration two analogue channels are available: one for the displacement transducer and the other for the load cell with closed-loop feedback, which controls application of the required pressure using a high precision stepper motor.

The unit can be controlled either by the **6" touch screen colour display** (to be ordered separately with product code 26-WF31E20/T) or via a computer (not included) were the **SOIL MASTER** software (to be ordered separately as alternative to the touch screen display, product code 26-WF31E20/SW) shall be installed.

Adding the **6" touch screen colour display**, the **ACE EmS** can be used as a stand-alone apparatus, without the need of PC for test execution, USB pen drive is also included for unlimited storage capacity with output data in tabular TXT format.

Test parameters are pre-programmed and saved in the **ACE EmS** memory by the operator, including the test end, which can be programmed on a time or increment basis.

The software **SOIL MASTER** can control up to 60 **ACE EmS** units from a single PC, giving the operator the choice of controlling single or multiple units.

Once the software is installed with the first **ACE EmS** unit, it is possible to extend the control of further units just by enabling the communication without additional interventions and costs: an IP address is given to each unit for the LAN communication: system modularity is ensured for subsequent integrations.

Calibrations of displacement transducers and load cells are performed and saved as txt file. Up to 10 points of calibration can be recorded for each channel.

Test results are recorded and displayed in real time. Test data can be processed using the proper Geo-Analysis Templates conforming to BS or ASTM Standards.

The frame can accept all standard consolidation cells, from 50.47 to 112.80mm diameter. Consolidation cells, Geo-Analysis templates and test software are not included. See Accessories. PC is not included.

The machine is supplied complete with the following electronic transducers:

- 20 kN capacity load cell
- 10 mm displacement transducer.

Optional upgrade kit is also available for performing Constant rate of strain consolidation with pore pressure control, using one pressure controller Hydromatic single and pore pressure measurement.

Optional upgrade kit is also available for performing unconfined Test, consisting of upper and lower platen.

Main features:

- **Electromechanical Servoactuation**, no dead weights nor air compressor required
- Fully automatic PC-controlled test execution with software program **SOIL MASTER** (to be ordered separately);
- Maximum vertical force: **20 kN**
- Automatic “next step” actuation driven by **time, swelling or secondary consolidation rate**
- **10 mm** displacement transducer measuring vertical settlement
- **20 kN** capacity Load cell measuring vertical force
- **Optimized PID closed-loop control** delivering fast smooth and accurate loading and precise load holding through the multiple test steps
- Infinitely variable speed
- **Remote PC control via LAN port** with dedicated software compatible with up to **60 independent units** running contemporaneously
- Compatible with consolidation cells up to **112.80 mm dia.**
- **Optional** accessories available for **CRS and Unconfined** test (additional data acquisition devices are not required)
- **Optional** local user interface with **6” touch screen** high resolution color display allowing full control of a single unit including full test execution. USB pen drive included for unlimited storage, TXT format data output

Ordering code:

26-WF31E20 ACE EmS – Electromechanical Servoactuation, automatic oedometer machine. 220-110 V / 50-60 Hz / 1 Ph.

Accessories:

Consolidation cell and accessories.*

Code 26-	WF0320	WF0321	WF0325	WF0326	WF0335
Sample diameter [mm]	50.47	63.5	71.40	75	112.8
Height [mm]	20	20	20	20	25
Area [mm²]	20.00	31.67	40.00	44.16	100.00
Calibration Disk 26-	WF0320/9	WF0321/9	WF0325/9	WF0326/9	WF0335/9

* it includes loading pad, 2 porous stones, clamping ring, and cells.

Software

Important: either the software or the local user interface (see below) are mandatory for running the machine.

26-WF31E20/SW

ACE EmS PC software activation code.

For remote control and data acquisition from up to 60 ACE EmS.

Key features:

- Remote control of all the testing phases
- Numerical and graphical displaying of results
- Advanced routines for sensors Calibration and verification
- Up to 10 calibration points recordable for each sensor
- Tests saving and flexible data base functions

26-WF31E20/T

Optional local user interface with 6" touch screen high resolution color display allowing full control of a single ACE EmS including full test execution.

- No need of PC and software 26-WF31E20/SW for test execution
- Numerical and graphical display of the readings
- Data are recorded on USB pen drive for unlimited storage capacity. TXT format data output

Data processing templates

30-WF6016/T1 Oedometer Geo-Analysis template to BS 1377:5

30-WF6016/T8 Oedometer Geo-Analysis template to ASTM D2435

30-WF6016/T8A Direct and residual Shear Geo-Analysis template to ASTM D4546

Accessories for additional tests

26-WF31E20/E

ACE EmS extension roads and centering pin for CRS (Constant rate of strain) and Unconfined (UC) test

Note: CRS cell, pressure controller, pore pressure transducers and de-airing block shall be ordered separately

26-WF31E20/U

Upper and lower platens with mounting bracket for Unconfined (UC) test with ACE EmS.

Note: if necessary, a 25mm displacement transducer shall be ordered separately.



NOTE:

This manual describes the use of the ACE equipped with the user interface **6" touch screen colour display**. If the ACE is controlled via PC and SOIL MASTER software program please refer to the relevant manual.

The device must be used in compliance with the procedures described in this manual. Never use the device for purposes different from those herewith indicated.

Please read this manual thoroughly before you start using the equipment.

1.1 Icons appearing in the manual

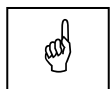

This icon indicates a **NOTE**; please read thoroughly the items marked by this picture.





This icon indicates a **WARNING message**; the items marked by this icon refer to the safety aspects of the operator and/or of the service engineer.

1.2 Manual revision history

Revision/Date	Change description
Rev. 1 22 nd January 2018	Manual release

1.3 Symbols used

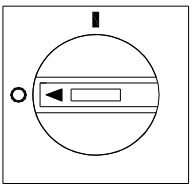
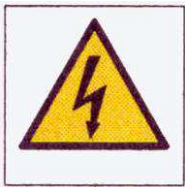
In this manual and on the equipment itself, apart from the symbols indicated on the control panel, also the following icons are used:

Symbol	Description
	Mains switch: O = device not connected to the mains line I = device connected to the mains line
	Dangerous voltage
	Hand injury
	Conformity to the CE Directive

1.4 Intended use and improper use

The **ACE EmS** can only be used to determine the rate and magnitude of consolidation of a soil specimen: restrained laterally and subjected to a number of successive increments of vertical loads or unconfined. These tests are carried out according to the following international standards: ASTM D2435 | ASTM D3877 | ASTM D 4546 | AASHTO T216 | BS 1377:5 | NF P94-091 | UNI-CEN-ISO 17892 Part5.

The unit is designed to be operated by one operator that has to install the necessary accessories, put the sample and start the test via the touch screen display that controls the unit (or via the PC, depending on the version ordered).

During normal operation the working area of the equipment is the top-front side and the relevant touch screen (or computer).

The operator is responsible of starting-up the equipment, performing the test sequence, shutting down the equipment and eventually stopping it in case any emergency conditions are met.

The operator must be trained on the correct use of the machine and the relative safety aspects of its use.

The machine should be used following the procedures described in this manual.

Never use the machine for reasons other than those for which it was designed and manufactured. Any other use of the machine is to be considered improper, not foreseen and hence dangerous.

CONTROLS will not be responsible for improper use of the machine.

1.5 Safety information

**WARNING:**

Please read this chapter thoroughly.

CONTROLS designs and builds its devices complying with the related safety requirements; furthermore it supplies all information necessary for correct use and the warnings related to use of the equipment.

CONTROLS will not to be held responsible for:

- use of the equipment different than the intended use;
- damages to the unit, to the operator, caused both by installation and maintenance procedures different than those described in this manual supplied with the unit, and by wrong operations;
- mechanical and/or electrical modifications performed during and after the installation, different than those described in this manual.

The unit is not designed to be used in an explosive atmosphere.

Installation and any technical intervention must only be performed by qualified technicians authorized by CONTROLS.

Only authorised personnel can remove the covers and/or have access to the components under voltage.

During normal use, if the operator detects irregularities or damages, he/she should immediately inform the authorized technical personnel.

Maintenance and service activities can only be performed by skilled authorized technical personnel that have been properly trained on the residual risks of the equipment.

It is responsibility of the purchaser to make sure that the operators have been properly instructed concerning the safety issues and the residual risks related to the equipment.

The following table lists those parts of the equipment that may present some residual risks for the safety of the personnel if the instructions provided in this manual are not duly followed.

Personnel	Area with residual risks
Operator	During the execution of the test-preload phase, the little gap between the rod attached to the loadcell and the top cap of the consolidation cell, due to the possibility of pinching the fingers when the rod and the top cap get in touch.
	Remember not to pour water on any part of the machine.
	At the end of the test, the gap between the consolidation cell table and the upper part of the case of the unit, due to the possibility of crushing the fingers when the table returns to its rest position.
Technical personnel	Above listed areas
	Areas around compartments closed by removable panels
	Areas around compartments that contain electrical parts and hydraulic devices
	For continued fire protection, replace fuses with same type and rating. Also, in case of failure, components may only be replaced by using original spare parts. It is in the responsibility of the purchaser to insure that fire prevention policies are properly implemented according to the CE provisions.
Personnel responsible of transportation and moving of the equipment	Raising and moving of the equipment from the shipping box must be performed by people properly trained and equipped with suitable personal protection devices (e.g. gloves, helmet, etc.). Failure to follow the instructions above may endanger the personnel involved.

Here follows a list of all WARNINGS present in the manual; please see relevant chapters for full details on each related safety issue.

**WARNING:**

When operating with the covers open/removed and the unit is attached to the mains line, care must be taken as high voltage is present in some parts of the unit (e.g. electrical panel). Only authorized and qualified service technicians are allowed to open /remove covers.

**WARNING:**

All safety devices must be functional at all time. Damaged protective covers or devices must be replaced immediately. When safety components are replaced, the protective devices are to be properly attached and tested. Any manipulation of the safety devices endangers the operating personnel.

**WARNING:**

Raising and moving of the equipment must be performed by people properly trained and equipped with suitable personal protection devices (e.g. gloves, helmet, etc.). Failure to follow the instructions above may endanger the personnel involved.

**WARNING:**

If the instructions to remove the equipment from the shipping box are not carefully followed, damages to the equipment cabinet may result. This will void the warranty terms of the equipment.

**WARNING:**

Do not stand under suspended loads

**WARNING:**

If the equipment is brought from a cold environment into a heated room, condensation on and in the unit, can constitute a danger and lead to malfunctioning of the unit when started. Wait to connect and operate the unit until it is at room temperature.

**WARNING:**

The general grounding must comply with the rules in force; a wrong quality of the grounding could be dangerous for the operator's safety and cause bad function of the electrical devices.



WARNING:

Covers/doors can only be removed/opened by maintenance people, by using relevant tools/keys. These tools and keys are for use by maintenance personnel only. Never leave the tools and keys attached to the unit as this may endanger operator safety.

After performing maintenance/repair, make sure that all covers/doors are properly closed and locked.



WARNING:

It is recommended that the operator perform the specified maintenance actions before each session of operations.

If the operator detects irregularities or damage, he should immediately inform the Maintenance department.



WARNING:

The calibration of the **26-WF31E20 ACE EmS** can only be performed by authorized **CONTROLS** technical personnel. **CONTROLS** will not be held responsible for damages to the equipment due to the unauthorized execution of the procedures here after described.



WARNING:

PID button is reserved to **CONTROLS** technical personnel. Do not access this function unless specifically authorized by **CONTROLS** Technical personnel. **CONTROLS** will not be held responsible for damages to the equipment due to the unauthorized access of this function.



WARNING:

At the start of the preload phase, the loading rod of the loadcell will suddenly come in touch with of the top cap of the consolidation cell. Keep hands/fingers away from the area to avoid pinching (residual risk).



WARNING:

After pressing the **HOME button** at the end of the test, the loading plate of the oedometer will suddenly move down towards the upper surface of the case of the unit. Keep hands/fingers away from the area to avoid pinching (residual risk).

**WARNING:**

Failing to perform the recommended maintenance actions or maintenance performed by unauthorized people can void the warranty. CONTROLS will not be responsible for maintenance and service actions performed by unauthorized people.

**WARNING:**

Before opening/removing the covers, disconnect the mains supply to the device and wait at least 5 minutes.

**WARNING:**

For continued fire protection, replace fuses with same type and rating. Also, in case of failure, components may only be replaced by using original spare parts. It is in the responsibility of the purchaser to ensure that fire prevention policies are properly implemented according to the CE provisions.

**WARNING:**

Refer to qualified service organization authorized by CONTROLS to carry out the service maintenance actions described in the chapter “Diagnostic and Troubleshooting”. CONTROLS has not to be held responsible for damages to the equipment and/or injuries to personnel in case the above is not strictly followed.

**WARNING:**

When operating with the unit attached to the mains line, care must be taken as high voltage is present in some parts of the unit (e.g. electrical components). Avoid splashing water on the live parts of the machine.

1.6 Environmental risks and disposal



INFORMATION TO THE OWNER OF THE EQUIPMENT

The above symbol, when attached to the equipment or to the relevant packaging, indicates that the product must be disposed of separately from other rubbish at the end of the useful life.

Therefore, at the end of its useful life, the owner should dispose of the product in a suitable collection point for electrical and electronic products provided by the local authorities.



The correct disposal of this product and the subsequent treatment encourages the manufacture of products using re-cycled materials and limits the environmental impact of the product caused by improper disposal.

Improper disposal of the product is subject to penalties as foreseen by the local regulations.

Please refer to the local laws and regulations for proper disposal of the product.

1.7 CE declaration

This page shows a copy of the CE declaration. The original is supplied with the equipment as a separate document.

DECLARATION OF CONFORMITY DICHIARAZIONE DI CONFORMITÀ		
<i>Directive 2006/42/CE, Annex II, sub A) - Direttiva 2006/42/CE, Allegato II, parte A)</i>		
Manufacturer <i>Fabbricante</i>	CONTROLS S.P.A. WYKEHAM FARRANCE Division	
Address <i>Indirizzo</i>	Via Salvo D'Acquisto 2/4, 20060 Liscate, (MI) Italy	
Herewith declares that the machine <i>Dichiara che la macchina</i>		
Model <i>Modello</i>	26-WF31E20	
Serial number <i>Matricola</i>	17008835	
Description <i>Descrizione</i>	ACE EmS - Electromechanical Servoactuation, automatic oedometer machine. 220-100 V / 50-60 Hz/ 1 PH <i>ACE EmS - Sistema servo-controllato completamente</i> <i>Automatico per prove di consolidazione.</i> 220-100 V / 50-60 Hz/ 1 PH	
		
is in conformity with the provisions of the following EC directives: <i>è conforme a quanto previsto dalle seguenti direttive CE:</i>		
2006/42/CE (Machinery Directive) <i>(Direttiva Macchine)</i>		
2014/35/UE (Low Voltage Directive) <i>(Direttiva Bassa Tensione)</i>		
2014/30/UE (Electromagnetic Compatibility Directive) <i>(Direttiva Compatibilità Elettromagnetica)</i>		
Date of issue <i>Data di emissione</i>	Nicola Lezzerini Technical Director - Person authorized to compile the technical file Direttore tecnico - Persona autorizzata alla costituzione del fascicolo tecnico 	Established 1941 Wykeham Farrance <i>SOIL MECHANICS TESTING MADE EASY</i>
14 November 2017		
<small>CONTROLS S.p.A. Via Salvo D'Acquisto 2/4, 20060 Liscate (MI) Tel. +39- 02921841 fax +39- 0292103333 e-mail: controls@controls.it www.controls.it</small>		

2. DESCRIPTION

Refer to the following figures while reading this chapter.



Fig. 2-1

Ref	Description
1	Vertical loading system cross beam
2	Spirit level
3	Status leds
4	Touch screen Display (optional code 26-WF31E20/T)

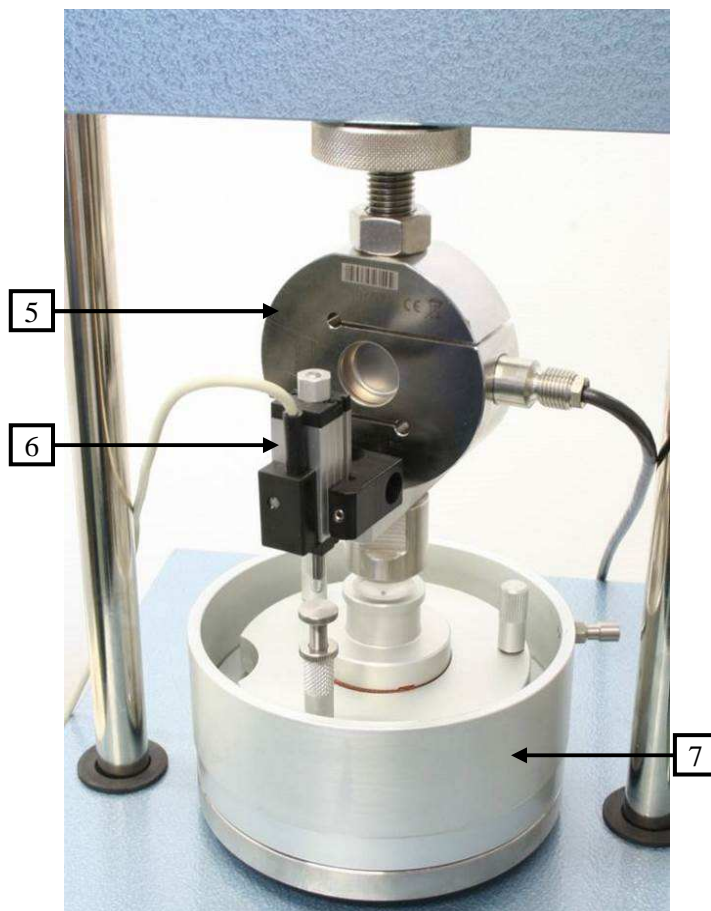

Fig. 2-2

Ref	Description
5	Loadcell
6	Displacement transducer
7	Consolidation cell with accessories

2.1 Connections

The next figure shows the position of the connectors/ports used to connect the equipment with the external devices.

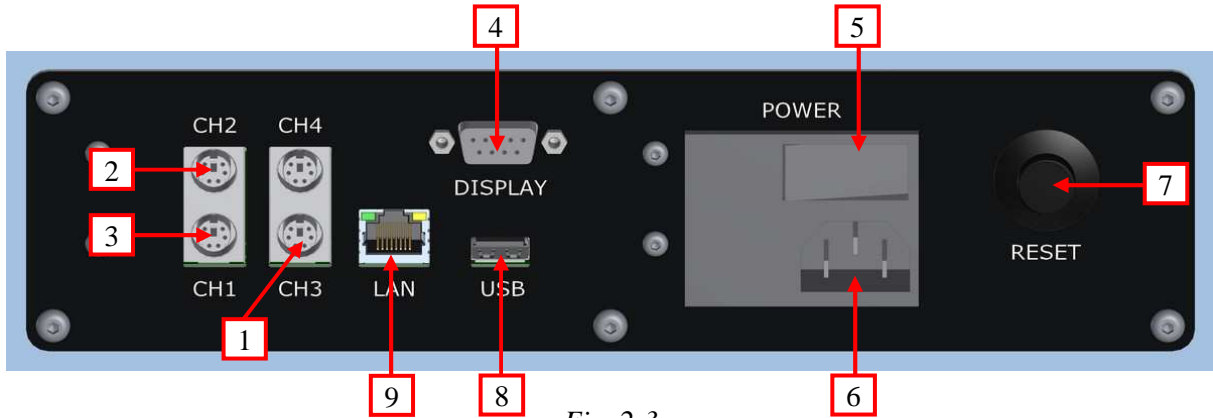

Fig. 2-3

Ref.	Descrizione
1	Displacement transducer connector (<i>CH3</i>)
2	Loadcell connector (<i>CH2</i>)
3	Pressure transducer for CRS test (<i>CH1</i>)
4	<i>DISPLAY</i> connector
5	<i>POWER</i> switch
6	<i>POWER</i> supply socket
7	<i>RESET</i> button
8	<i>USB</i> port
9	<i>LAN</i> connector

2.2 Identification plate

The identification plate is located on the rear panel near the power cord socket.



Fig. 2-4

2.3 Technical specifications

General features	
Product	ACE EmS
Manufacturer	CONTROLS Liscate (MI) Italy
Product code	26-WF31E20
Rated line voltage	110VAC - 220VAC +6%, -10%
Line frequency	50-60Hz
Maximum power	30W
Method of power entry	Cable
Computer connection	LAN
Max vertical load	20 kN
Platen travel	25 mm
Displacement transducer	11 mm
Horizontal Clearance	175 mm
Vertical Clearance	w/o 185 mm extension columns and 265 mm with extension columns
Minimum testing speed	0.00001 mm/min
Maximum testing speed	99.99999 mm/min
Sample dimensions	From 50.47 to 112.8 mm dia. With suitable consolidation cell
Software (not included)	27-WF21E80/SW to control up to 60 oedometers
Test data accuracy	±1%
Acoustic pressure	< 70db(A)
Net weight	46 Kg approx.
Width (W)	290 mm
Depth (D)	395 mm
Height (H)	635 mm

Environmental conditions	
Operating temperature	+ 10 ÷ + 40°C
Operating humidity	≤ 50%RH @ 40°C

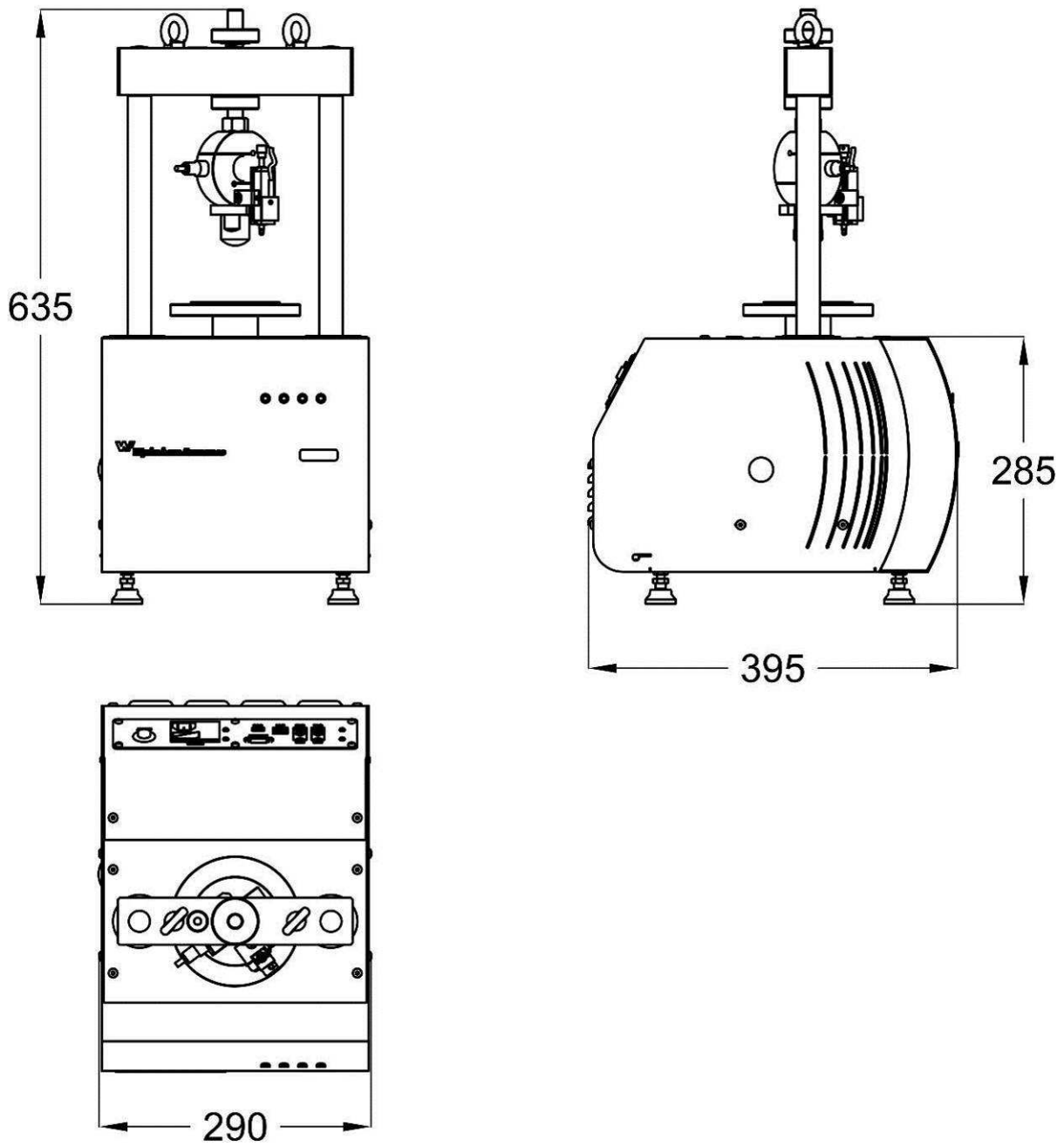

Fig. 2-5

3. INSTALLATION

The instructions indicated in this chapter enable you to perform a correct installation and interfacing in order to grant a regular operation of the equipment. Included are initial inspection procedure, power requirements and instructions for installing the unit.

The information in this chapter is intended for authorized service-trained personnel.

CONTROLS can supply the assistance and the necessary technical advice for pre-installation, all the pre-installation phases are at the purchaser's charge and must be performed complying with the indications given below.



WARNING:

When operating with the covers open/removed and the unit is attached to the mains line, care must be taken as high voltage is present in some parts of the unit (e.g. electrical panel). Only authorized and qualified service technicians are allowed to open /remove covers.



WARNING:

All safety devices must be functional at all time. Damaged protective covers or devices must be replaced immediately. When safety components are replaced, the protective devices are to be properly attached and tested. Any manipulation of the safety devices endangers the operating personnel.

3.1 Shipment

The **ACE EmS** unit is normally shipped in a carton box with wooden base having the following dimensions: 530 mm x 460 mm x 700 mm (W x D x H).

The gross weight (including shipping/packaging materials) is 54 Kg approx.

Use a proper mean to raise and move the box.



WARNING:

Raising and moving of the equipment must be performed by people properly trained and equipped with suitable personal protection devices (e.g. gloves, helmet, etc.). Failure to follow the instructions above may endanger the personnel involved.

3.2 Unpacking and inspection

The unit was carefully checked both mechanically and electrically before shipment; it should be inspected for any damage that may have occurred in transit.



NOTE:

If the shipping container or packaging material is damaged, it should be kept until the unit has been mechanically and electrically checked.

If there is mechanical damage and/or the contents are incomplete (see the shipping list), please notify the local CONTROLS representative.

If the shipping container is damaged or shows sign of stress, notify the carrier as well as the CONTROLS representative. Save the shipping material for carrier's inspection. Also take some pictures.

Here follows the procedure for the unpacking of the equipment

3.2.1 How to remove the equipment from the shipping crate

The following table shows the net weight of the different models of the equipment:

Model	Net weight
26-WF31E20	46 Kg approx.

Follow the instructions below to remove it from the shipping crate:

1. Inspect shipping crate (see NOTES above);
2. Open the shipping crate;
3. Cut and remove vacuum bag (if present) to expose the equipment;
4. The equipment must only be lifted up by means of the 2 eye bots and using ropes positioned as shown in drawing below. Do not lift it by any other part to avoid damaging the equipment (see
5. Fig. 3-1).

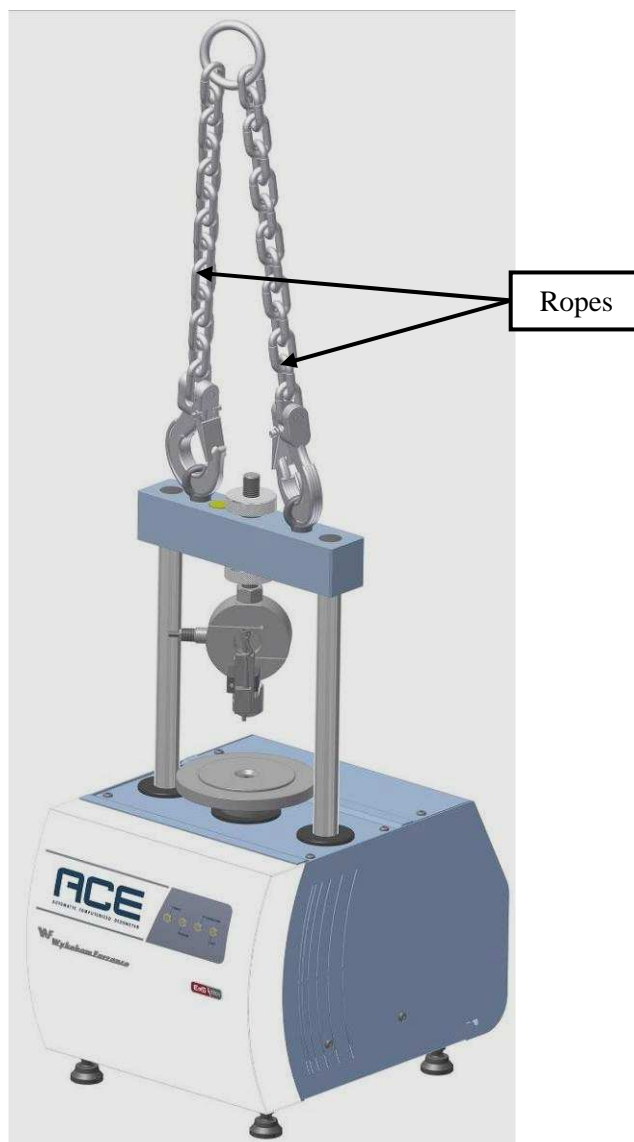

Fig. 3-1



WARNING:

If the instructions to remove the equipment from the shipping box are not carefully followed, damages to the equipment cabinet may result. This will void the warranty terms of the equipment.



WARNING:

Raising and moving of the equipment must be performed by people properly trained and equipped with suitable personal protection devices (e.g. gloves, helmet, etc.). Failure to follow the instructions above may endanger the personnel involved.



WARNING:

Do not stand under suspended loads

6. Before powering on the unit, check for loose connections of cables inside the equipment.

3.3 Positioning of the unit and space requirements

The area around the equipment must be kept free from obstacles and from substances that may cause sliding of the personnel.

It is responsibility of the purchaser to provide an installation place with adequate lighting.

Parts used to build the machine and electrical/electronic component are fire-proof. It is anyway the responsibility of the owner of the equipment to make sure that the installation place is equipped with proper fire extinguishing systems and that the operators have been instructed on the relevant procedures.

Use a proper mean to bring the unit to the installation place.

The site should have a solid platform, not subject to shock or vibration. Where compaction equipment etc. is used nearby, it is recommended that a rectangular section of floor should be cut out, lined with polystyrene slabs (or other vibration damping material) and filled back with concrete to form a vibration-proof platform. In any case, where a bench is used, a small piece of rubber sheet placed under each foot would be a wise precaution. A normal laboratory bench should be available nearby for preparation of samples and cell.

Place the apparatus on a bench that can support its weight along with the various accessories, is horizontal and a suitable height for easy and safe use.

Place the unit in its final location, taking into account the free space around the unit: the equipment requires at least 50 cm of clearance on the rear side for maintenance and service purposes.

Also consider that the electrical connections are located on the rear panel of the equipment.

The unit requires adequate air circulation around it to assure proper cooling of the internal devices.

**WARNING:**

If the equipment is brought from a cold environment into a heated room, condensation on and in the unit, can constitute a danger and lead to malfunctioning of the unit when started. Wait to connect and operate the unit until it is at room temperature.

3.4 Electrical requirements

The next table shows the electrical specifications of the equipment:

Item	Specifications
Single-phase voltage	110-220VAC +6%, -10%
Frequency	50-60Hz 1 Ph
Maximum power	30W

The equipment shall be connected to a proper earth system, the efficiency of which shall be checked by qualified personnel. Earth shall be via the power cord, as specified above.



WARNING:

The general grounding must comply with the rules in force; a wrong quality of the grounding could be dangerous for the operator's safety and cause bad function of the electrical devices.

The power supply line shall be equipped with a safety device (breaker and ground fault switch) properly sized with respect to the electrical specifications provided above.

3.5 Installing the displacement transducer

The unit is shipped with the loadcell already installed while the displacement transducer needs to be mounted on the unit;



Fig. 3-2



Fig. 3-3

Fix the displacement transducer holder to the bracket by means of the screw supplied;



Fig. 3-4

Tighten the fixing screw;



Fig. 3-5

Later on, rotate the consolidation cell in order to align the tip of the displacement transducer stem with the head of the reference screw.



Fig. 3-6

3.6 Electrical connection

The following sockets are available on the rear panel of the equipment:

- Displacement transducer connector (**CH3**): for connection of vertical displacement transducer;
- Loadcell connector (**CH2**): for connection of vertical loadcell;
- Pressure transducer (**CH1**): for connection of pressure transducer for CRS test;
- **DISPLAY** connector: for connection of the touchscreen display (optional code **26-WF31E20/T**);
- **POWER** switch: for turning-on the machine;
- **POWER** supply socket: connect it to a suitable electrical power outlet having the minimum specifications as described in previous chapter 3.4 and using the power cord supplied with the equipment;
- **RESET** button: for by-passing overtravel microswitch, if the motor is located in overtravel position;
- **USB** port: for connection of USB memory stick; use for storage data results of test;
- **LAN** connector: for connection with the PC; use the shielded LAN cable provided with the equipment (do not use non-shielded cables otherwise the system may not work properly. For detailed information about the software, refer to the relevant Instruction Manual).

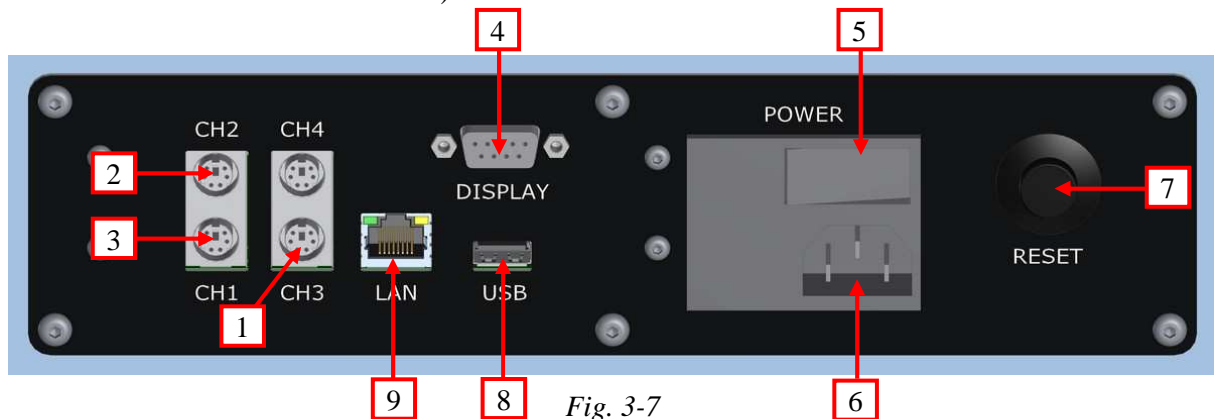
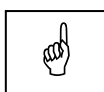

Fig. 3-7

Ref.	Descrizione
1	Displacement transducer connector (CH3)
2	Loadcell connector (CH2)
3	Pressure transducer for CRS test (CH1)
4	Touchscreen DISPLAY connector
5	POWER switch
6	POWER supply socket
7	RESET button
8	USB port
9	LAN connector



NOTE:

If more than one **ACE EmS** unit is controlled by the same PC, LAN switch(es) must be used. Connect all **ACE EmS** units to the LAN switch ports and use one port on the LAN switch to connect to the PC. A maximum of 60 **ACE EmS** units can be connected, via LAN switches, to one PC. Complex systems may require more than one LAN switch to be used (see examples of connection in figure below). Use only LAN switches that supports 10/100/1000 Mbit per second speed otherwise the system may not work properly.

Example of system with 1 LAN switch

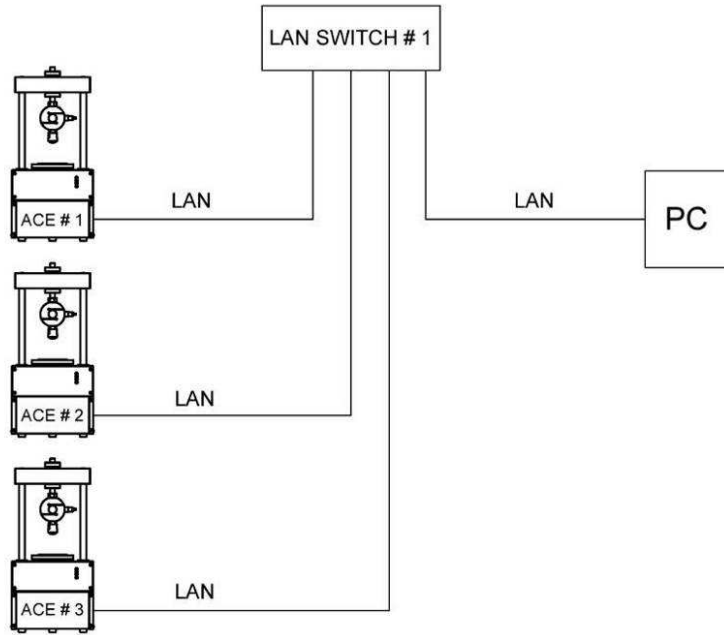

Example of system with multiple LAN switches

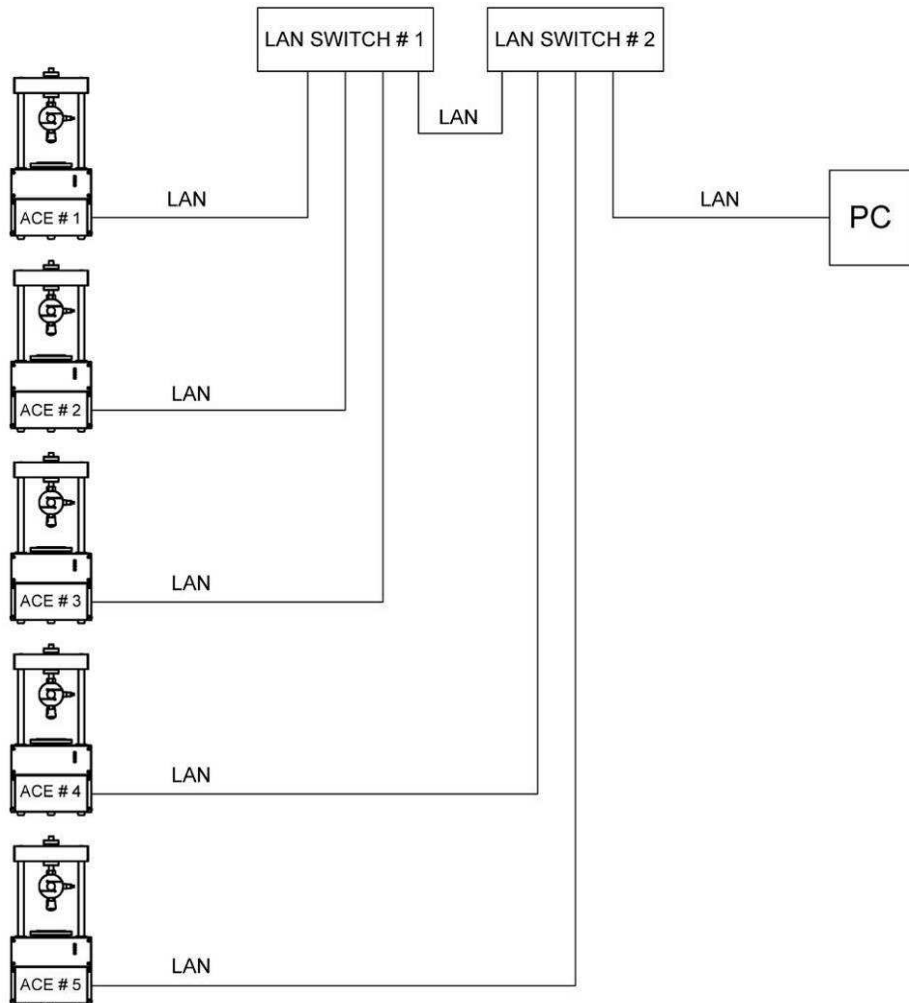

Fig. 3-8 (Examples of connection to the PC)

4. USE OF THE EQUIPMENT

This chapter describes the operator's interface of the touch screen display (optional code **26-WF31E20/T**). If the machine is used with the PC, refer to the instruction manual of the software.



WARNING:

All safety devices must be functional at all time. Damaged protective covers or devices must be replaced immediately. When safety components are replaced, the protective devices are to be properly attached and tested. Any manipulation of the safety devices endangers the operating personnel.



WARNING:

Covers/doors can only be removed/opened by maintenance people, by using relevant tools/keys. These tools and keys are for use by maintenance personnel only. Never leave the tools and keys attached to the unit as this may endanger operator safety.

After performing maintenance/repair, make sure that all covers/doors are properly closed and locked.



WARNING:

It is recommended that the operator perform the specified maintenance actions before each session of operations.

If the operator detects irregularities or damage, he should immediately inform the Maintenance department.



WARNING:

When operating with the unit attached to the mains line, care must be taken as high voltage is present in some parts of the unit (e.g. electrical components). Avoid splashing water on the live parts of the machine.

4.1 Switching ON the equipment

Firstly, turn-on the machine by pushing the switch on the rear side, near the power cord receptacle: the following screen appears on display.



Fig. 4-1

Next screen appears after *ACE EmS* Logo. It is a **SYSTEM MESSAGE** to remind that the USB memory stick, for storage data results, is not inserted or detected.

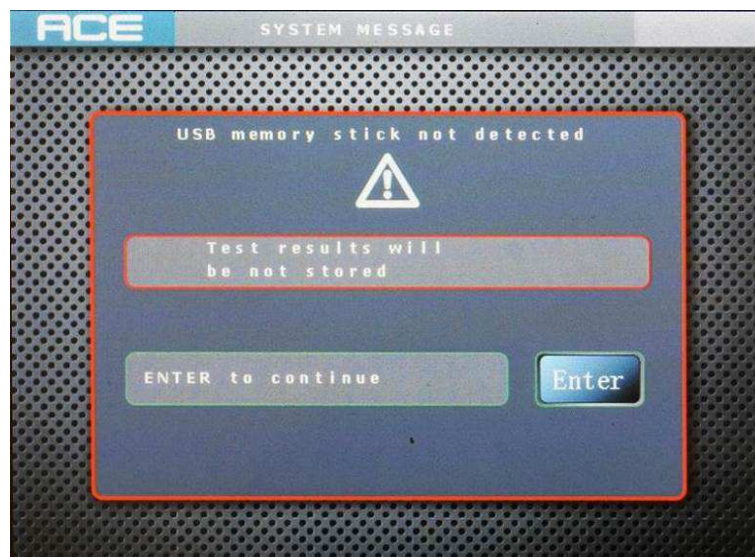

Fig. 4-2

Press the **ENTER** button to access the **MAIN MENU**.



NOTE:

The touchscreen should be operated using the stylus provided. Hitting the touchscreen heavily may damage it. Never use a pen or a sharp object as damage to the equipment may result. The warranty will be void if the screen is damaged due to improper use.

4.2 MAIN MENU description

This section describes the distinct functions of the touchscreen interface that is used to control the *ACE EmS* in stand-alone mode.

The *MAIN MENU* is shown when the unit is switched-on and can be returned to by closing other panels.

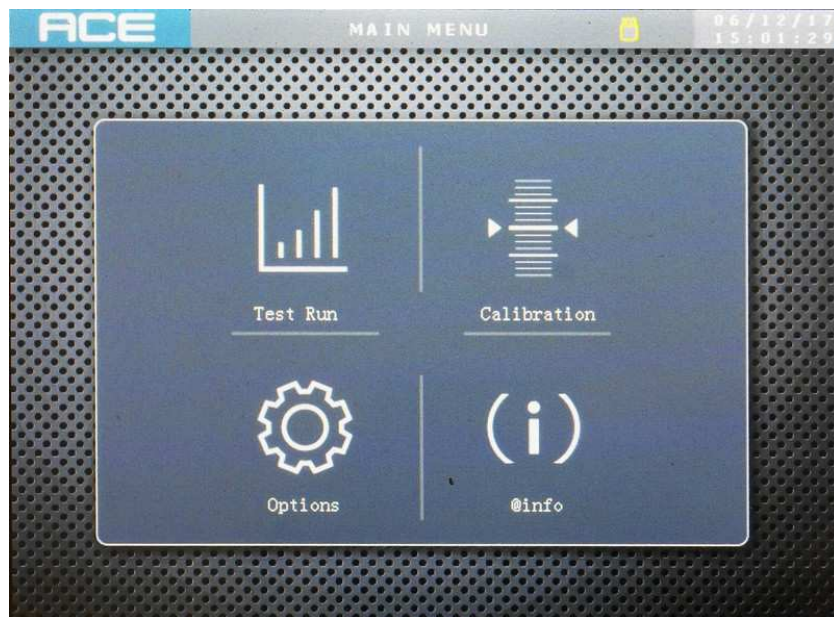

Fig. 4-3

From the *MAIN MENU*, four options can be selected:

- **TEST RUN** - to select logging intervals and test start/stop conditions, zero readings and run a test (see section 4.2.1);
- **OPTIONS** - to set the date and time and IP address of the unit, to change the display language and to manage the USB memory stick (see section 4.2.2);
- **CALIBRATION** - to perform the calibrations (see section 4.2.3);
- **@INFO** - to view CONTROLS company information, firmware version, IP address of oedometer, the relative Hydromatic IP address (only for CRS test) and subnet mask, for PC connection (see section 4.2.4).

Next chapters provide details on each of the options mentioned above.

4.2.1 TEST RUN description



Select the **TEST RUN** icon from the **MAIN MENU** to open **SELECT TYPE OF TEST** where is it possible to select among:

- **OEDOMETRIC CONSOLIDATION TEST** (see section 4.2.1.1);
- **UNCONFINED TEST** (see section 4.2.1.2).

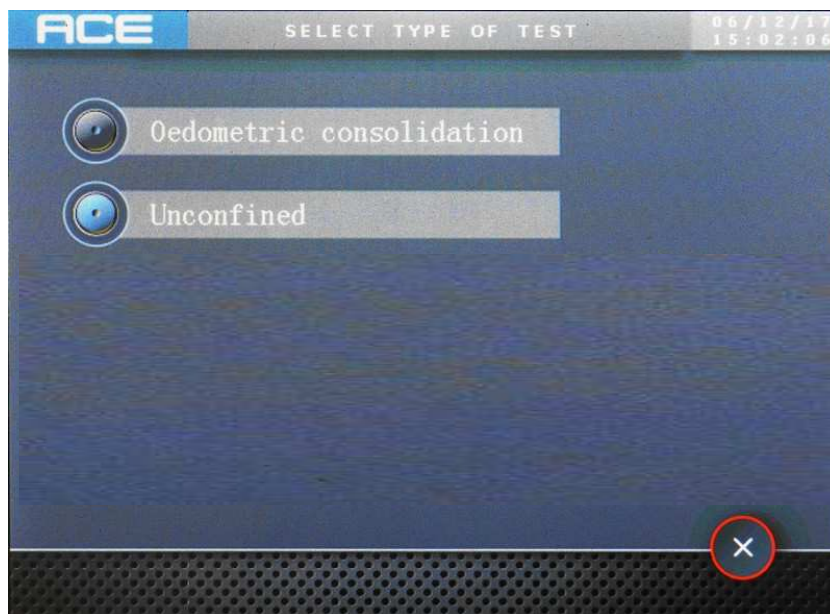

Fig. 4-4

4.2.1.1 OEDOMETRIC CONSOLIDATION TEST

In the **OEDOMETRIC CONSOLIDATION TEST**, a soil specimen laterally restrained, is subjected to several steps of axial pressure and left to consolidate for each of them.

Once the **OEDOMETRIC CONSOLIDATION TEST** option has been accessed, the system shows the following screen.

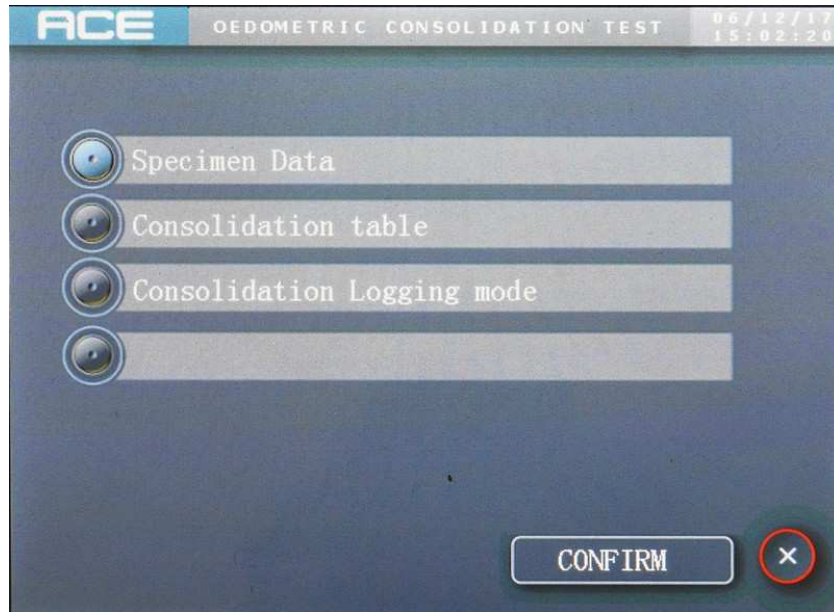



Fig. 4-5

 This button is pressed to close the page and return to the previous screen (any changes are saved automatically).



NOTE:

All the numbers/data of the following screens can be changed by tapping the number and entering a new value using the **KEYBOARD** (refer to section 4.4 for more details on the use of the **KEYBOARD**). All next buttons of this operator's interface, turns blue when the mode is selected.

4.2.1.1.1 SPECIMEN DATA

The following screen refers to the first option of **OEDOMETRIC CONSOLIDATION TEST** screen.

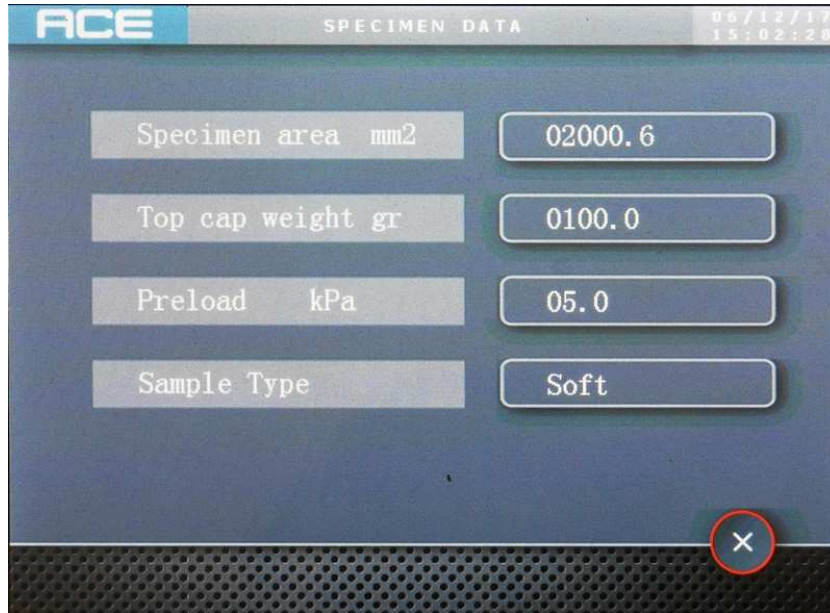

Fig. 4-6

In this screen, it is possible to insert/change:

- **SPECIMEN AREA (mm²)**: insert value of the specimen area for the test;
- **TOP CAP WEIGHT (g)**: insert the weight value of the loading cap of the consolidation cell;
- **PRELOAD (kPa)**: insert value of preload pressure;
- **SAMPLE TYPE**: choose from **Soft** sample type or **Hard** sample type.

4.2.1.1.2 CONSOLIDATION TABLE

The following screen refers to the second option of **OEDOMETRIC CONSOLIDATION TEST** screen.

01/10	Target	R. T (min)	Swell. T. (min)	Thr.	T. (min)
00012	01440	00.010	00010	00.000	00010
00025	01440	00.010	00010	00.000	00010
00050	01440	00.000	00010	00.000	00010
00100	01440	00.000	00010	00.000	00010
00200	01440	00.000	00010	00.000	00010
00400	01440	00.000	00010	00.000	00010
00800	01440	00.000	00010	00.000	00010
01600	01440	00.000	00010	00.000	00010
03200	01440	00.000	00010	00.000	00010
00800	00720	00.000	00010	00.000	00010

Fig. 4-7

In this screen, tap on the left side of each consolidation step (blue light on) and insert/change:

- the **TARGET** pressure (*kPa or psi*) that will be applied to the specimen;
- the relevant **TIME** (*min*) along which the consolidation step is maintained constant;
- the **SWELLING** (*mm*): i.e. the limit of swelling; if this limit is exceeded the system automatically stops the step and apply the next step of consolidation;
- the relevant **TIME** interval (*min*) to control the swelling (usually 1 min.);
- the **THRESHOLD** and the related **TIME** interval to stop skip automatically to the next step of consolidation.

The values in the above table are for a sample of 50mm dia. They are just an example.



NOTE:

When values in columns **SWELL.** and **THR** are set to **0**, the relevant step will be disabled.



NOTE:

The settlement threshold and the related time interval indicate the rate of settlement vs. time. If this rate of settlement is lower than a limit set by the user (e.g. 0.01 mm for 100 min), the system automatically stops the step and start the next step.

4.2.1.1.3 CONSOLIDATION LOGGING MODE

The following screen refers to the third option of **OEDOMETRIC CONSOLIDATION TEST** screen.

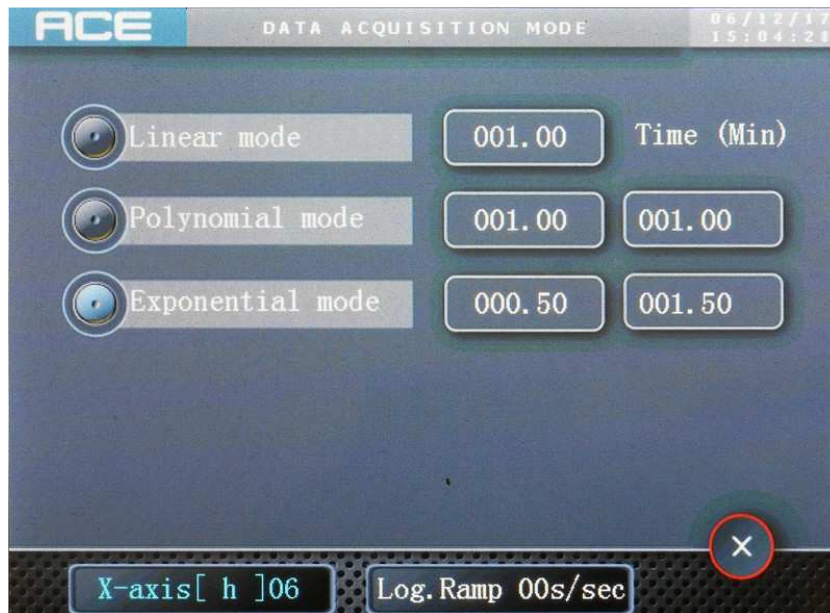

Fig. 4-8

This screen is for setting the logging intervals for data acquisition.

The logging mode is selected by tapping the button on the left of the required option; the button turns blue when selected. Only one option can be selected from the following:

- **LINEAR MODE** - to log readings (in min.) at constant intervals. Input the interval (in min) in the cell on the right. For example: enter 2.00 min to get readings at 2.0, 4.0, 6.0, 8.0 minutes.
- **POLYNOMIAL MODE** – to log readings (in min.) with the formula $A \times (r.n.)^B$, where **A** is the value entered in the 1st (left) adjacent cell, **B** is the value in the 2nd second (right) cell and r.n. is the reading number, starting from 1.
For example: with **A** = 0.25 & **B** = 2 the readings will be at 0.25, 1, 2.25, 4, 6.25, 9, 12.25, 16, minutes, suitable for a BS1377 consolidation stage;
- **EXPONENTIAL MODE** – to log readings (in min.) with the formula $A \times B^{(r.n.)}$, where **A** is the value entered in the 1st (left) adjacent cell, **B** is the value in the 2nd (right) cell and r.n. is the reading number, starting from 1.
For example: with **A** = 0.05 & **B** = 1.5 the readings will be at 0.08, 0.11, 0.17, 0.25, 0.38, 0.57, 0.85, 1.28, 1.92, minutes;
- **LOG. RAMP 00S/SEC** - select this mode to change the number of readings per second (i.e. 5 readings per second) for logging data during the ramps.



NOTE:

In addition to the reading of consolidation, the system also can record the measurements of the transducers during the application of the ramp of pressure. This option can be disabled by tapping on the cell and insert “00s/sec” as value of Log. Ramp. (Max is 10).

The **X-AXIS SCALE** button is for setting the maximum scale of the x axis of the graph. The scale can be changed by tapping on the text until the required value is shown: the options are: 1 min, 5 mins, 15 mins, 30 mins, 1 hour, 6 hours and 24 hours.



If you select “X-axis[min]01”, you can change the time scale with the **KEYBOARD**.

Once all parameters for the test have been entered, press  to return to the **OEDOMETRIC CONSOLIDATION TEST** screen.

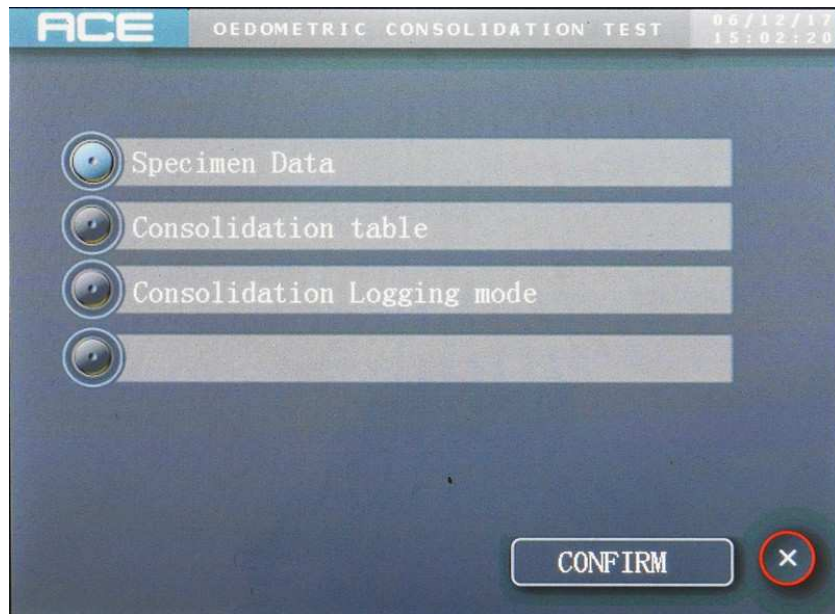

Fig. 4-9

Finally, press **CONFIRM** button in **OEDOMETRIC CONSOLIDATION TEST** screen, to open the following screen and start the test.



Fig. 4-10

The following buttons are available at the bottom of the screen before logging is started:

- **START** - for starting data logging;
- **PARAMETERS** - for opening the **OEDOMETRIC CONSOLIDATION TEST screen** where the data logging intervals can be managed;
- **FILENAME** - for entering a filename for the logged data;



NOTE:

Data will only be saved if a USB memory stick is plugged into the unit. Data are stored in a tab-separated .txt file. The filename can be up to 8 characters long and must not contain any spaces.

- **SKIP** - for skipping a step of consolidation.

The following buttons are available on the right of the screen for controlling the stepping motor before test is started:

- **DOUBLE / SINGLE ARROWS** – to drive manually the motor;
- **HOME** – for returning to home position and for positioning the vertical frame completely upwards;
- **STOP** – to stop the homing movement;

There is also a **TEST INFO box** – to display the condition of the system (type, stage, speed, etc.).

For each channel, the following information are displayed on the left of the screen:

Ref.	Description
1	Live transducer reading The decimal places and measurement units are set in the CALIBRATION screen . When the reading is within the upper and lower limits during logging, the background of the cell is green; if the reading goes out of this range the background turns red. Before starting the test/logging, tap on the reading to open the CHANNEL SETTINGS screen where the limits are set.
2	Name of transducer For viewing the name of the relative transducer: Load or Displacement .
3	ZERO button , for zero/unzero setting the live readings of the transducers. This button is only available before data logging starts. If a zero offset is applied, the transducers readings will be relative to this offset.
4	H2O button , for zero/unzero setting the live readings of the transducers, immediately after placing the water in the consolidation cell for the swelling. This button is only available before data logging starts. If a zero offset is applied, the transducers readings will be relative to this offset.
5	Bar and threshold During swelling and consolidation readings, there's a coloured bar that grows up till a certain threshold value placed on the right side.

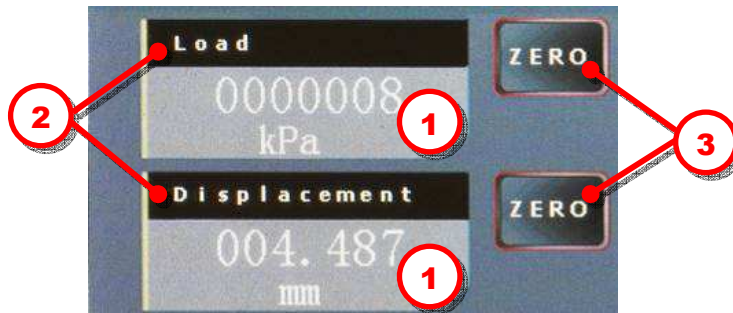

Fig. 4-11

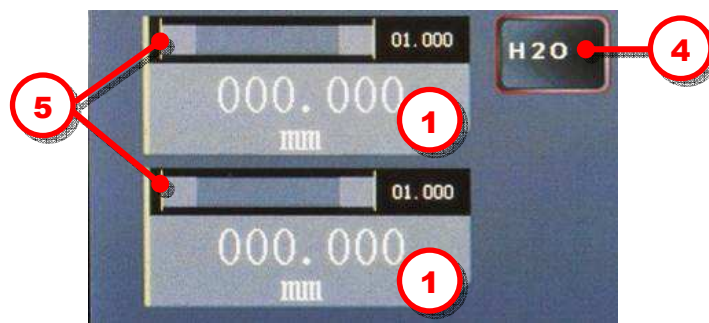

Fig. 4-12

4.2.1.2 UNCONFINED TEST

In the **UNCONFINED TEST**, a soil specimen is subjected to a unique step of axial pressure and left to consolidate.

Once the **UNCONFINED TEST** option has been accessed, the system shows the following screen.

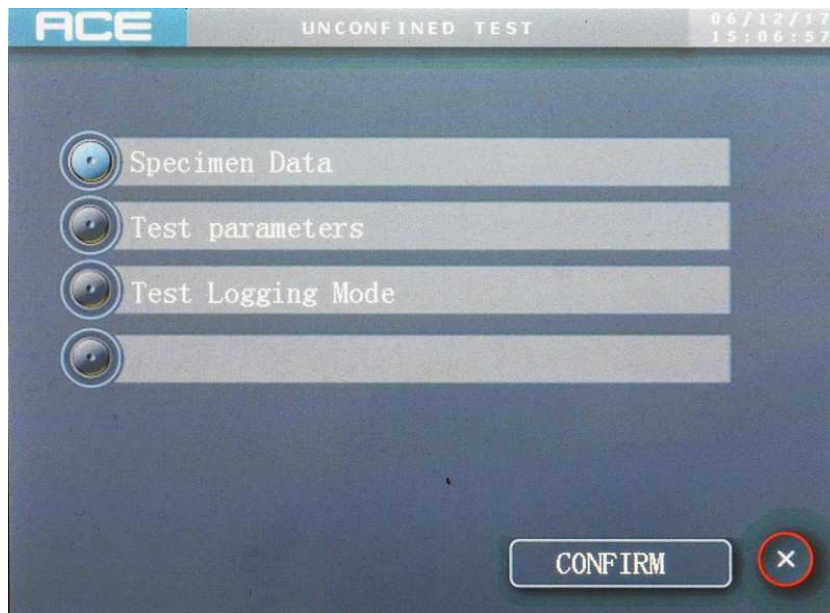



Fig. 4-13

 This button is pressed to close the page and return to the previous screen (any changes are saved automatically).

 **NOTE:**
All the numbers/data of the following screens can be changed by tapping the number and entering a new value using the **KEYBOARD** (refer to section 4.4 for more details on the use of the **KEYBOARD**). All next buttons of this operator's interface, turns blue when the mode is selected.

4.2.1.2.1 SPECIMEN DATA

The following screen refers to the first option of **UNCONFINED TEST** screen.

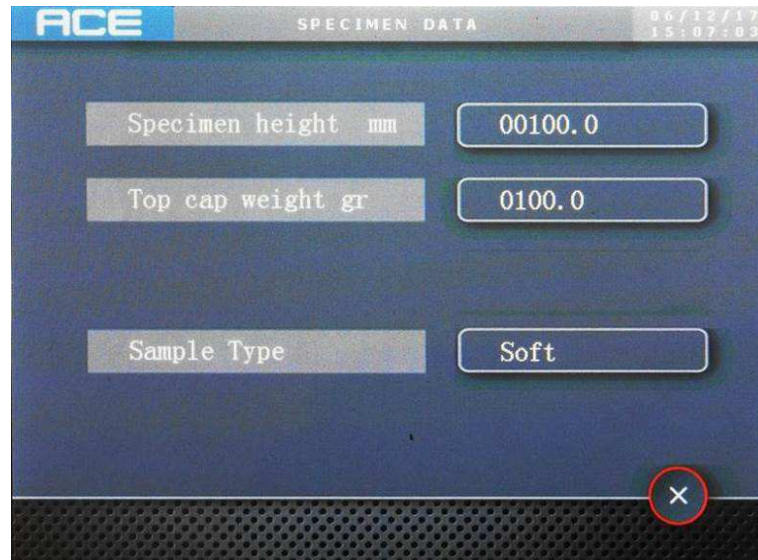

Fig. 4-14

In this screen, it is possible to insert/change:

- **SPECIMEN HEIGHT (mm)**: insert value of the specimen height for the test;
- **TOP CAP WEIGHT (g)**: insert the weight value of the loading cap;
- **SAMPLE TYPE**: choose from **Soft** sample type or **Hard** sample type.

4.2.1.2.2 TEST PARAMETERS

The following screen refers to the second option of **UNCONFINED TEST** screen.

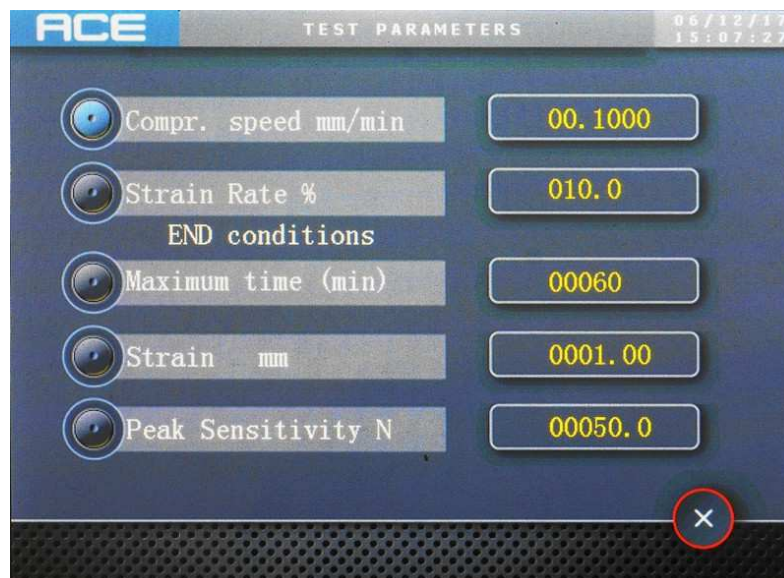

Fig. 4-15

In this screen, the operator can choose between two types of speed settings, by tapping on the left side of each options (blue light on) and insert/change:

- the **COMPR. SPEED (mm/min)**: insert the standard speed in mm/min;
- the **STRAIN RATE (%)**: insert the strain rate in %;

Below, it is possible to choose the **END CONDITIONS** of the **UNCONFINED TEST** by tapping on the left side of each options (blue light on) and insert/change:

- the **MAXIMUM TIME (min)**: duration in minutes of the step of consolidation;
- the **STRAIN (mm or %)**: amount of strain to reach, in mm if the operator chooses the **COMPR. SPEED** or in % if the operator chooses the **STRAIN RATE**;
- the **PEAK SENSITIVITY (N)**: amount of force in N, to reach before the failure.

The values in the previous screen are just an example.

4.2.1.2.3 TEST LOGGING MODE

The following screen refers to the third option of **UNCONFINED TEST** screen.

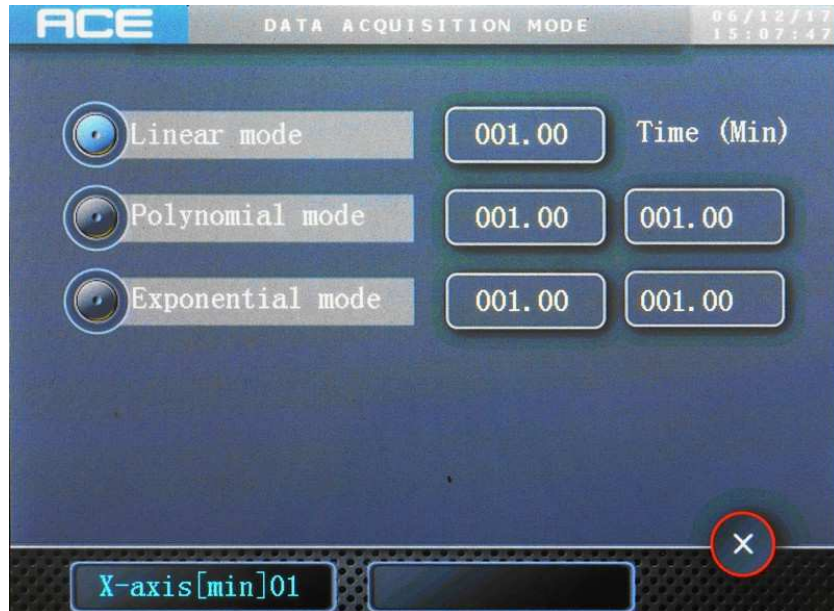

Fig. 4-16

This screen is for setting the logging intervals for data acquisition.

The logging mode is selected by tapping the button on the left of the required option; the button turns blue when selected. Only one option can be selected from the following:

- **LINEAR MODE** - to log readings (in min.) at constant intervals. Input the interval (in min) in the cell on the right. For example: enter 2.00 min to get readings at 2.0, 4.0, 6.0, 8.0 minutes.
- **POLYNOMIAL MODE** – to log readings (in min.) with the formula $A \times (r.n.)^B$, where **A** is the value entered in the 1st (left) adjacent cell, **B** is the value in the 2nd second (right) cell and r.n. is the reading number, starting from 1.
 For example: with **A** = 0.25 & **B** = 2 the readings will be at 0.25, 1, 2.25, 4, 6.25, 9, 12.25, 16, minutes, suitable for a BS1377 consolidation stage;
- **EXPONENTIAL MODE** – to log readings (in min.) with the formula $A \times B^{(r.n.)}$, where **A** is the value entered in the 1st (left) adjacent cell, **B** is the value in the 2nd (right) cell and r.n. is the reading number, starting from 1.
 For example: with **A** = 0.05 & **B** = 1.5 the readings will be at 0.08, 0.11, 0.17, 0.25, 0.38, 0.57, 0.85, 1.28, 1.92, minutes;

The **X-AXIS SCALE** button is for setting the maximum scale of the x axis of the graph. The scale can be changed by tapping on the text until the required value is shown: the options are: 1 min, 5 mins, 15 mins, 30 mins, 1 hour, 6 hours and 24 hours.



If you select “**X-axis[min]01**”, you can change the time scale with the **KEYBOARD**.

Once all parameters for the test have been entered, press  to return to the **UNCONFINED TEST** screen.

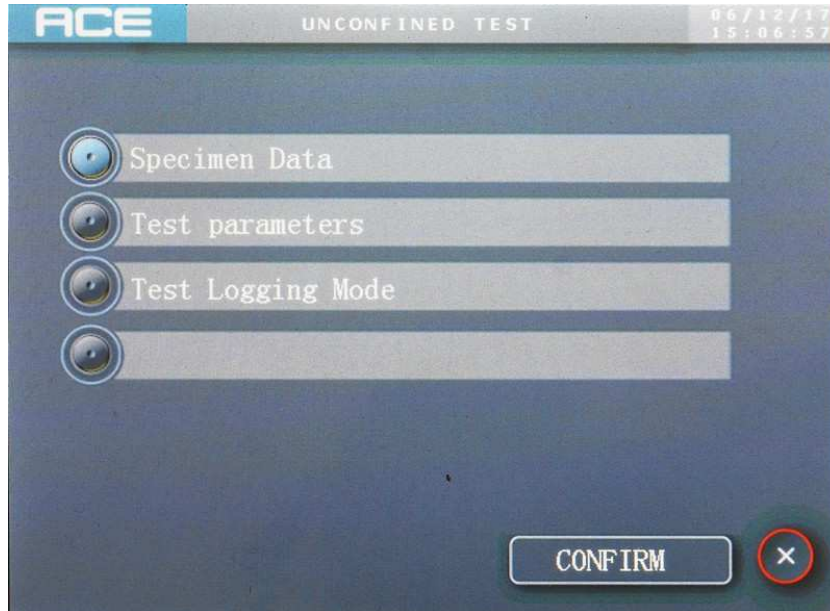

Fig. 4-17

Finally, press **CONFIRM** button in **UNCONFINED TEST** screen, to open the following screen and start the test.



Fig. 4-18

The following buttons are available at the bottom of the screen before logging is started:

- **START** - for starting data logging;
- **PARAMETERS** - for opening the **UNCONFINED TEST screen** where the data logging intervals can be managed;
- **FILENAME** - for entering a filename for the logged data;



NOTE:

Data will only be saved if a USB memory stick is plugged into the unit. Data are stored in a tab-separated .txt file. The filename can be up to 8 characters long and must not contain any spaces.

- **SKIP** - for skipping a step of consolidation.

The following buttons are available on the right of the screen for controlling the stepping motor before test is started:

- **DOUBLE / SINGLE ARROWS** – to drive manually the motor;
- **HOME** – for returning to home position and for positioning the vertical frame completely upwards;
- **STOP** – to stop the homing movement;

There is also a **TEST INFO box** – to display the condition of the system (type, stage, speed, etc.).

For each channel, the following information are displayed on the left of the screen:

Ref.	Description
1	Live transducer reading The decimal places and measurement units are set in the CALIBRATION screen . When the reading is within the upper and lower limits during logging, the background of the cell is green; if the reading goes out of this range the background turns red. Before starting the test/logging, tap on the reading to open the CHANNEL SETTINGS screen where the limits are set.
2	Name of transducer For viewing the name of the relative transducer: Load, Displacement or Speed .
3	ZERO button , for zero/unzero setting the live readings of the transducers. This button is only available before data logging starts. If a zero offset is applied, the transducers readings will be relative to this offset.

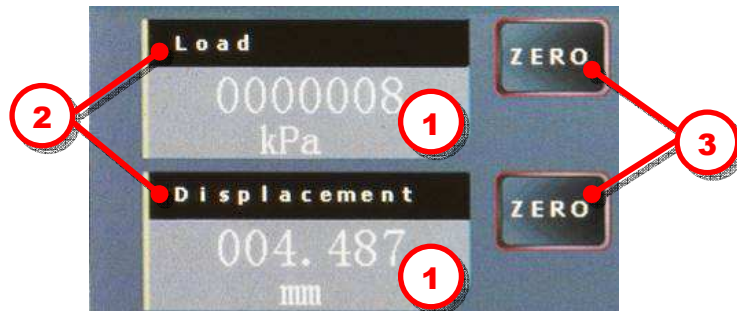

Fig. 4-19

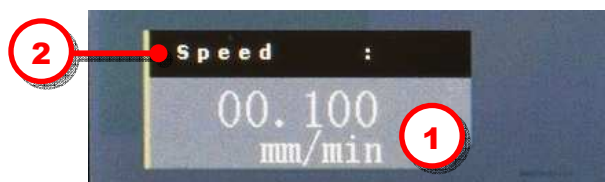

Fig. 4-20

Tap on the *Speed* reading to change the speed of the *UNCONFINED TEST*.

4.2.2 OPTIONS description



Selecting the **OPTIONS** icon from the **MAIN MENU** opens the **OPTIONS MENU**. The following settings can be managed from this menu.

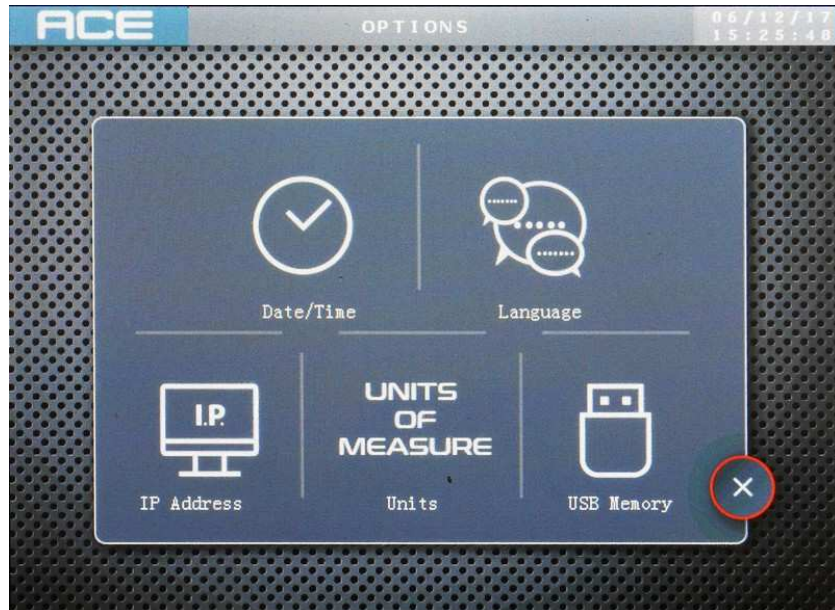

Fig. 4-21

- **DATE/TIME** - for changing the time and the date of the unit's internal clock.



Fig. 4-22

- **LANGUAGE** - for changing the display language.



Fig. 4-23

- **IP ADDRESS** - for changing the unit's IP address and Hydromatic IP address (this last IP is only for CRS test). The subnet mask is always: 255.255.255.0.



Fig. 4-24

- **UNITS** – for changing unit of measures: **Metric (mm, N, kPa)** or **Imperial (in, lbf, PSI)**.

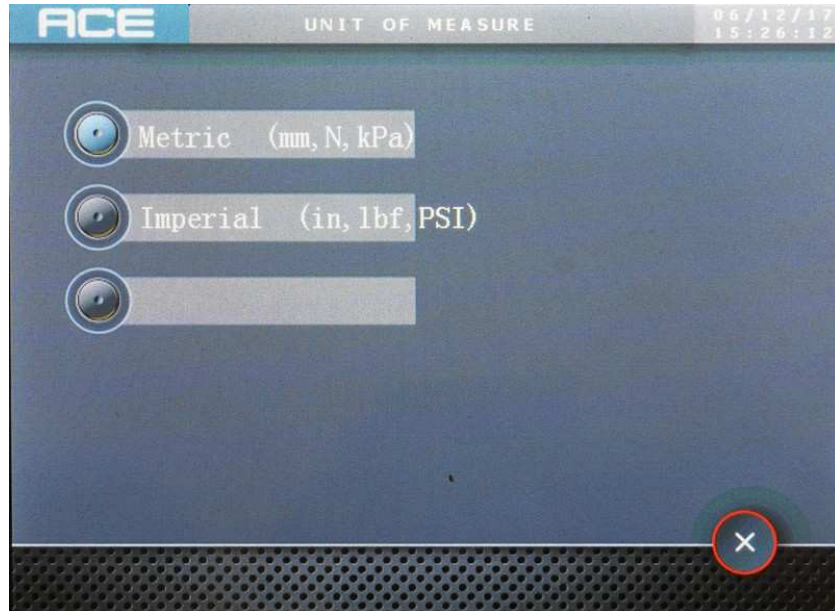

Fig. 4-25

After this screen, a **SYSTEM MESSAGE** appears asking to confirm measurement units.

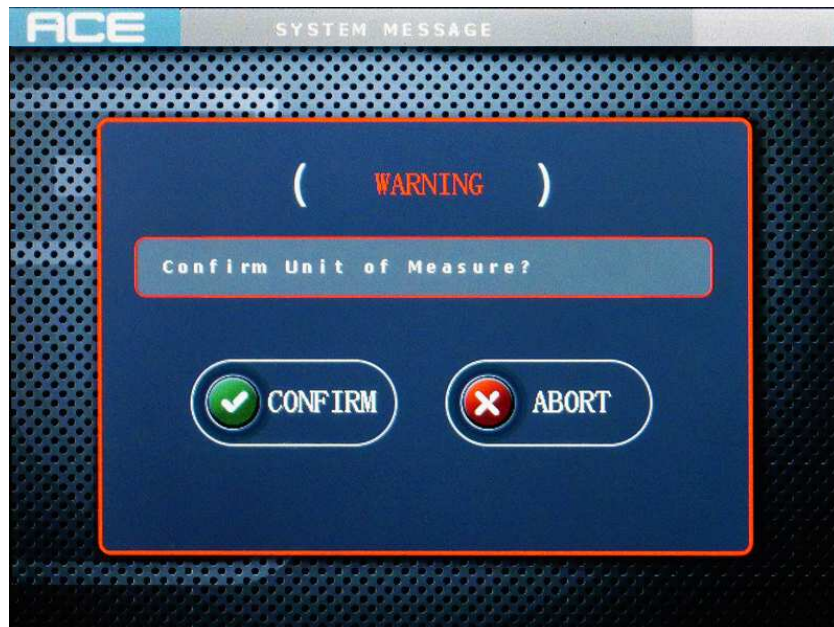

Fig. 4-26

- **USB MEMORY** - for selecting what action to be taken if no USB memory stick is found, and for managing the contents of the USB memory stick.



Fig. 4-27

When you press the delete button, a **SYSTEM MESSAGE** appears to ask confirmation before deleting data from the memory.

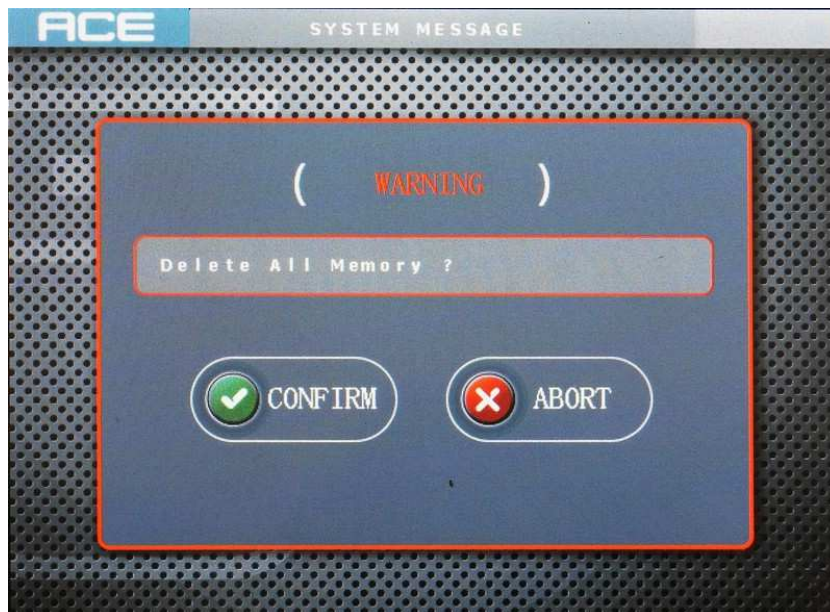

Fig. 4-28

A further confirmation is requested to the operator before deleting all data.

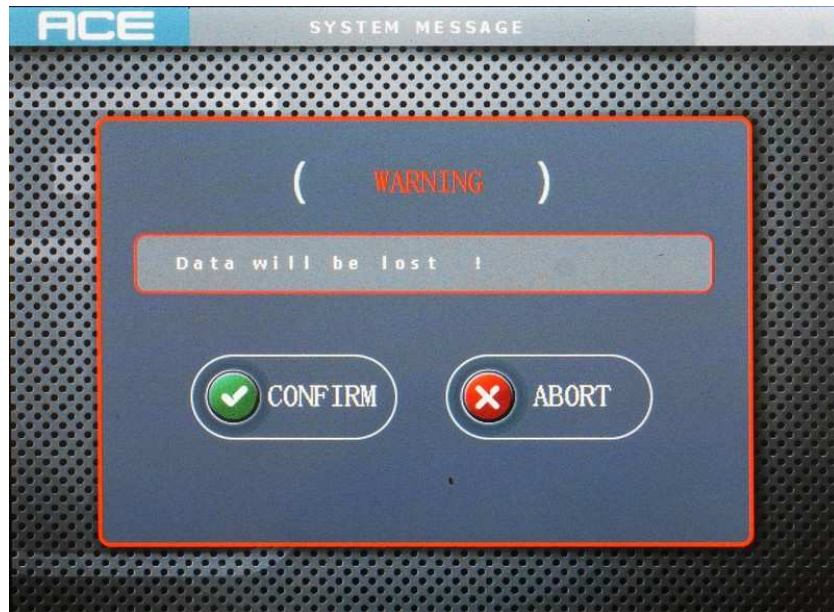

Fig. 4-29

4.2.3 CALIBRATION description



Selecting the **CALIBRATION** icon from the **MAIN MENU** opens the **CALIBRATION MENU**. From this screen, calibrations can be viewed or performed for each of the unit's four channels (by selecting the appropriate channel number button).

Also, a **MANUAL MODE** that allow you to insert all calibration parameters manually.

**NOTE:**

A password "00101" is required to edit the calibration data.



Fig. 4-30

**WARNING:**

The calibration of the **26-WF31E20 ACE EmS** can only be performed by authorized **CONTROLS** technical personnel. **CONTROLS** will not be held responsible for damages to the equipment due to the unauthorized execution of the procedures here after described.

4.2.3.1 Calibration screen

This screen is for viewing and performing a calibration on the transducer connected to the selected channel.

To view the screen, select the appropriate channel number button from the **CALIBRATION MENU**.

The selected channel number is shown in the **TITLE BAR**.



Fig. 4-31

To edit the data, you must select the **EDIT button** and enter the passcode '00101' with the **KEYBOARD**. This prevents data being changed accidentally.

Now, the following screen appears.

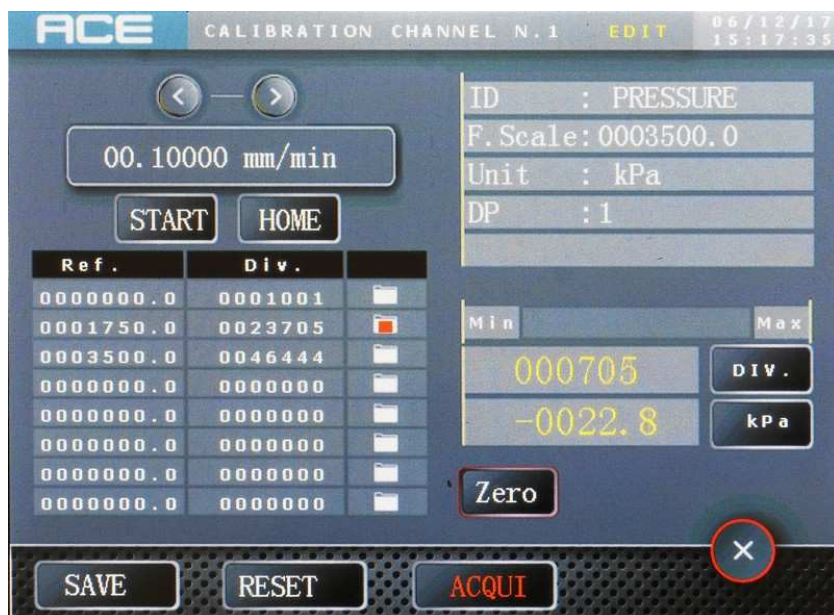

Fig. 4-32

The following buttons are available at the bottom of the screen:

- **EDIT** - for unlocking the sheet for editing;
- **SAVE** - this is shown after the sheet has been unlocked for editing and is for saving any changes made to the data;
- **RESET** - this is shown after the sheet has been unlocked for editing and is for clearing the data from the **CALIBRATION TABLE**. A message asks for confirmation;
- **ACQUI** – select with a red mark, a line in the third column of the table. Change manually the Ref. in the first column and after, start the calibration. Now, during the calibration press **ACQUI** for the acquisition of the Div. value, in the second column.

The table contains data for up to eight calibration points. The first (left) column is for entering the reference values, the readings of the reference equipment (e.g. micrometer, gauge blocks, pressure gauge), in measurement units. The values in this column can be changed by tapping the cell and entering a new value using the **KEYBOARD**. The second (middle) column displays the reading in divisions (bits) that corresponds to the reference reading. They are captured by tapping the icon in the corresponding row of the third (right) column.

If the operator resets the machine, the values (taken from the calibration file) must be entered manually.

During calibration, a colour bar graph appears showing the actual range between Min and Max.

4.2.3.1.1 Transducer details

These fields are for entering the following information about the transducer:

- **ID** - a name for the transducer: **LOAD**, **DISPLACEMENT**, **PRESSURE** and **HYDRO PRESSURE** (the last 2 used only in **MANUAL MODE** for generic pressure transducers);
- **F. SCALE** - the full scale/capacity of the transducer;
- **UNIT** - the measurement units that the transducer is reading;
- **DP** - the number of decimal places for displaying the transducer readings (on all screens).

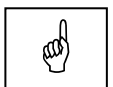
**NOTE:**

The values can be changed by tapping the field and entering a new value using the **KEYBOARD**.

4.2.3.1.2 Machine controller in calibration

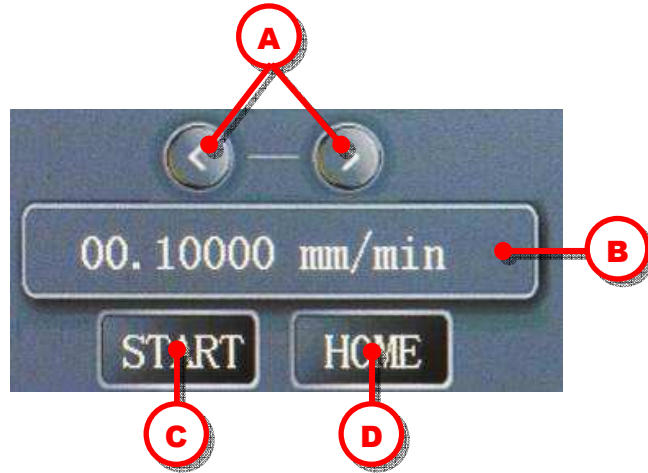



Fig. 4-33

- A. Hold buttons to perform manual approach upwards or downwards;
- B. Set the required speed;
- C. Press **START** to move the platen upward at the set speed; press it again (**STOP**) to stop the movement;
- D. **HOME**: Press to go to home position (downward).

4.2.3.1.3 Reading

The two cells display the live reading in divisions (bits) and in measurement units. The **ZERO** button is for zero-setting the reading in measurement units.

 This button is pressed to close the page and return to the previous screen (any changes are saved automatically).

The table below shows the hardware settings for some of the transducers most commonly supplied by CONTROLS:

CH	Transducer type	Capacity	Sensitivity	Input level	Voltage excitation
1	Load Cell	20 kN	2 mV/V	LOW (20 mV)	9 V
2	Displacement transducer	10 mm	1000 mV/V	HIGH (10 V)	10 V

Table 4-1

4.2.3.2 Manual Mode

This option is used to control the motor of the machine without data logging and to set the PID parameters.

Press Manual Mode from the *CALIBRATION MENU*. The following screen appears:

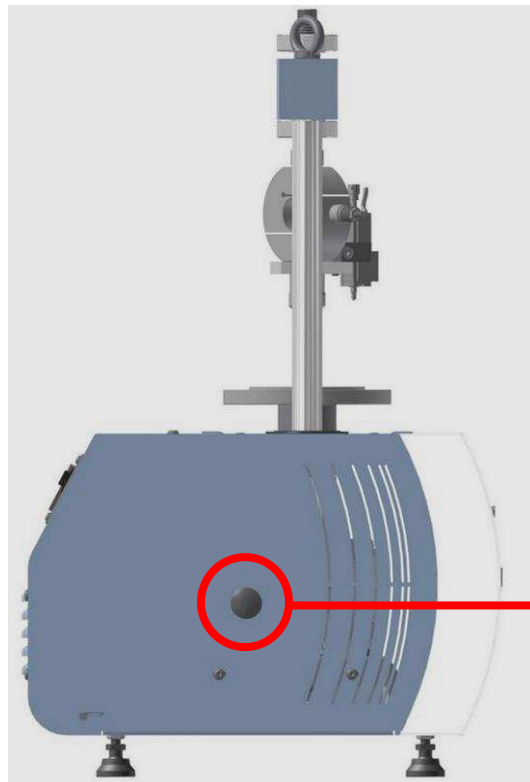

Fig. 4-34



NOTE:

Only in *MANUAL MODE* is possible to calibrate *PRESSURE* channel and *HYDRO PRESSURE* channel for generic transducers.



USE A KEY TO UNLOCK AND CALIBRATE MANUALLY THE MACHINE

Fig. 4-35

Press **PLAY** button and after, **MIN - MAX** bar become yellow.

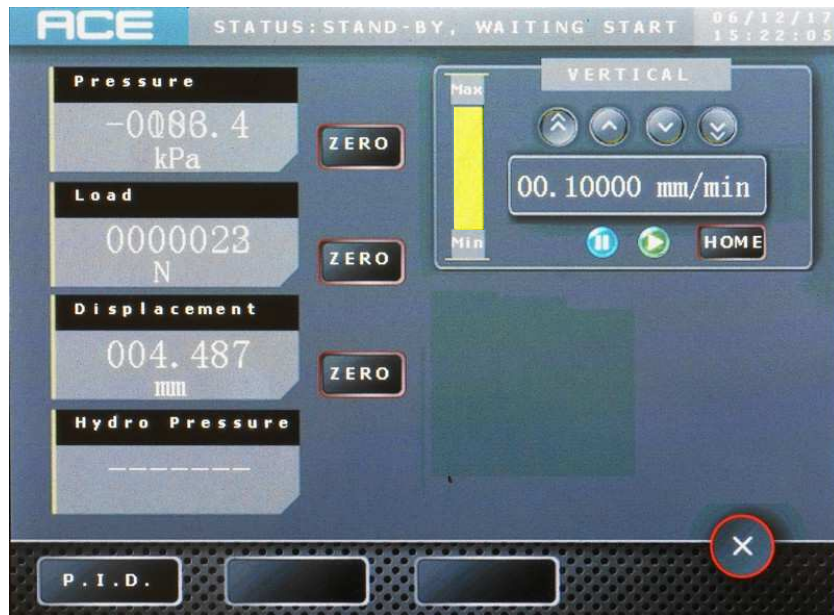

Fig. 4-36

Finally reach a **LIMIT**, marked in red.

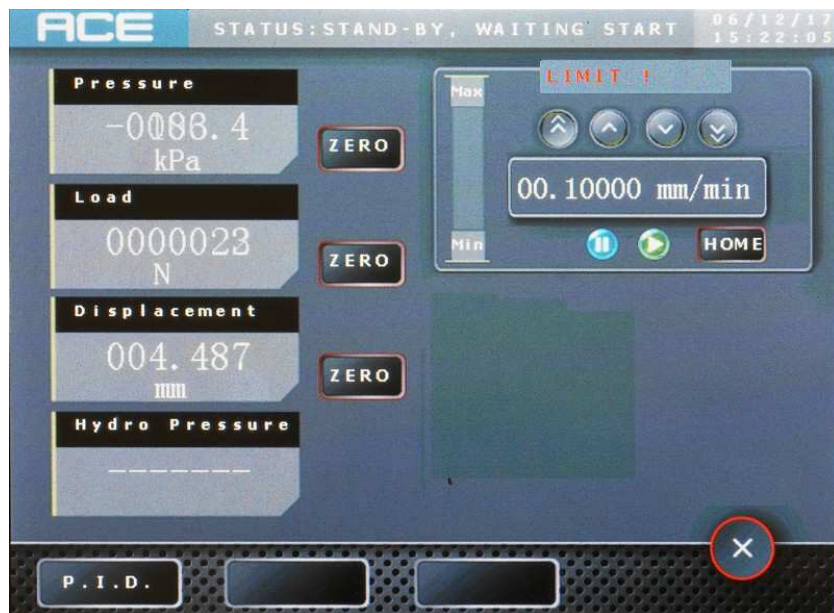

Fig. 4-37



WARNING:

PID button is reserved to CONTROLS technical personnel. Do not access this function unless specifically authorized by CONTROLS Technical personnel. CONTROLS will not be held responsible for damages to the equipment due to the unauthorized access of this function.

4.2.4 INFO description



From the **MAIN MENU** select the **@INFO** icon to display a screen showing **CONTROLS** company information, firmware version number, IP address and subnet mask for PC connection.

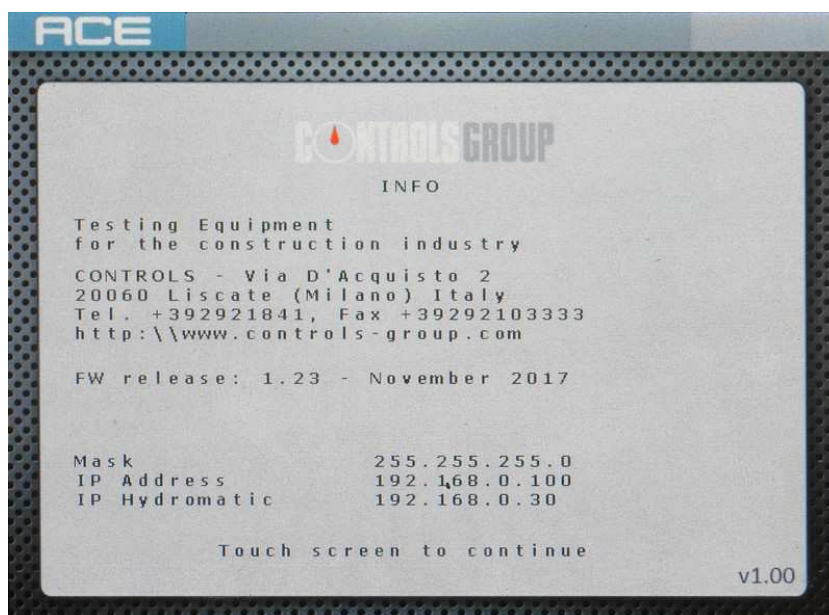



Fig. 4-38

4.3 TITLE BAR description

The *TITLE BAR* runs along the top of each screen and contains:

- The screen title or, during logging, the status and test file name, if applicable;
- The date and time according to the unit's internal clock (this can be set in the *OPTIONS*);
-  This icon is displayed if the unit has detected a USB memory stick connected;
-  This icon is displayed when the unit is connected to a PC via a LAN cable.

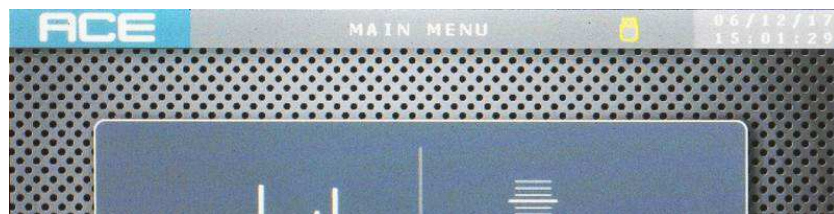

Fig. 4-39

4.4 KEYBOARD description

This screen automatically appears whenever something needs to be typed in. If the field is a text entry, the screen automatically displays a 'qwerty' **KEYBOARD**; if a number is required, a numerical **KEYBOARD** is displayed. Some of the keys are explained below.



Fig. 4-40

Ref.	Description
1	CURSOR buttons (for moving the cursor horizontally)
2	BACKSPACE key (for deleting characters)
3	ESC key (cancels the entry and closes the screen)
4	OK key (accepts the entry and closes the screen)
5	MODE key for switching between alphabet mode and numerical mode
6	SHIFT key (for typing in capital letters)

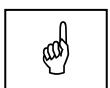

NOTE:

The filename must not contain any spaces, only letters and number can be entered as file name.

4.5 Carry out a test

4.5.1 Preparing the consolidation cell

The ACE EmS can accept all CONTROLS consolidation cells to perform either standard or permeability tests.

See table below for codes and specifications:

Model	Specimen Dia. x height mm	Specimen area Cm2	Cell dimension Dia. x height mm	Weight kg
26-WF0320	50.47x20	20	139x74	1.3
26-WF0321	63.50x20	31.67	139x74	1.3
26-WF0325	71.40x20	40	139x74	1.3
26-WF0326	75x20	44.16	139x74	1.3
26-WF0335	112.8x25	100	200x74	3

Here below the instruction to assemble the consolidation cell (refer to next drawing for cross-reference between steps and parts to be assembled):

1. Place the cell body on a bench and check that lower porous disk is clean and firmly inserted;
2. Place the adapter (needed only for consolidation cells codes WF0320 and WF0321);
3. Place correct-sized filter paper on the porous disk;
4. Place cutting ring with sample, edge up on the filter paper;
5. Place a second filter paper on the top of the sample;
6. Place clean upper porous disk on the filter paper;
7. Put top plate in position;
8. Rotate to align screw holes in top and bottom plates; insert the 3 long screws to hold cell assembly together;
9. Place top cap in hole in top plate.



WARNING:

When operating with the unit attached to the mains line, care must be taken as high voltage is present in some parts of the unit (e.g. electrical components). Avoid splashing water on the live parts of the machine.

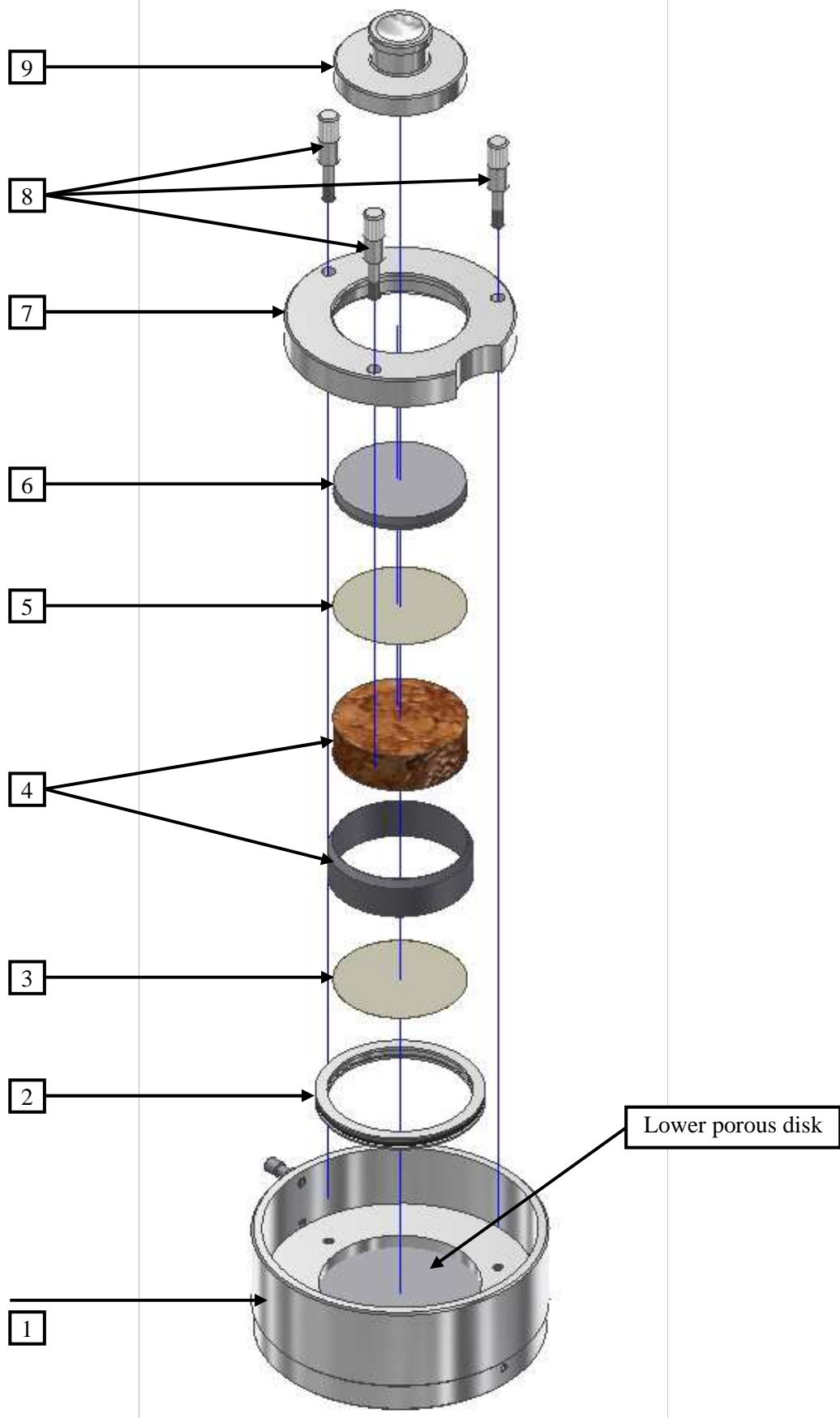

Fig. 4-41

4.5.2 Run the test

Here below the description of the sequence of operations to run a test. The present chapter only provides the main instructions and commands necessary to run the test:

1. On the consolidation cell previously prepared (see chapter 4.5.1) replace one of the 3 screws with the one supplied with the **ACE EmS**, equipped with small adjustable reference plate for the displacement transducer;



Fig. 4-42



Fig. 4-43

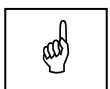

Fig. 4-44

2. Place the consolidation cell on the table of the **ACE EmS** unit;



Fig. 4-45



NOTE:

The displacement transducer can be left mounted on the machine (see chapter 3.5); just make sure not to damage the transducer stem while installing the consolidation cell on the plate.

3. Rotate the loadcell assembly in order to bring the displacement transducer stem over the knob with the small adjustable reference plate;



Fig. 4-46

4. Adjust the height of the loadcell assembly by acting on the two knurled lock nuts; the aim is to bring the rod of the loadcell at a distance of 1mm approx. from the top cap of the consolidation cell:
- To lower the loadcell assembly, unscrew the upper knurled lock nut by turning it counter-clockwise;
 - Push down the loadcell assembly (the threaded shaft is spring loaded) until getting the required gap between the rod of the loadcell and the top cap of the consolidation cell;
 - Turn the lower knurled lock nut counter-clockwise to fix the whole loadcell assy;

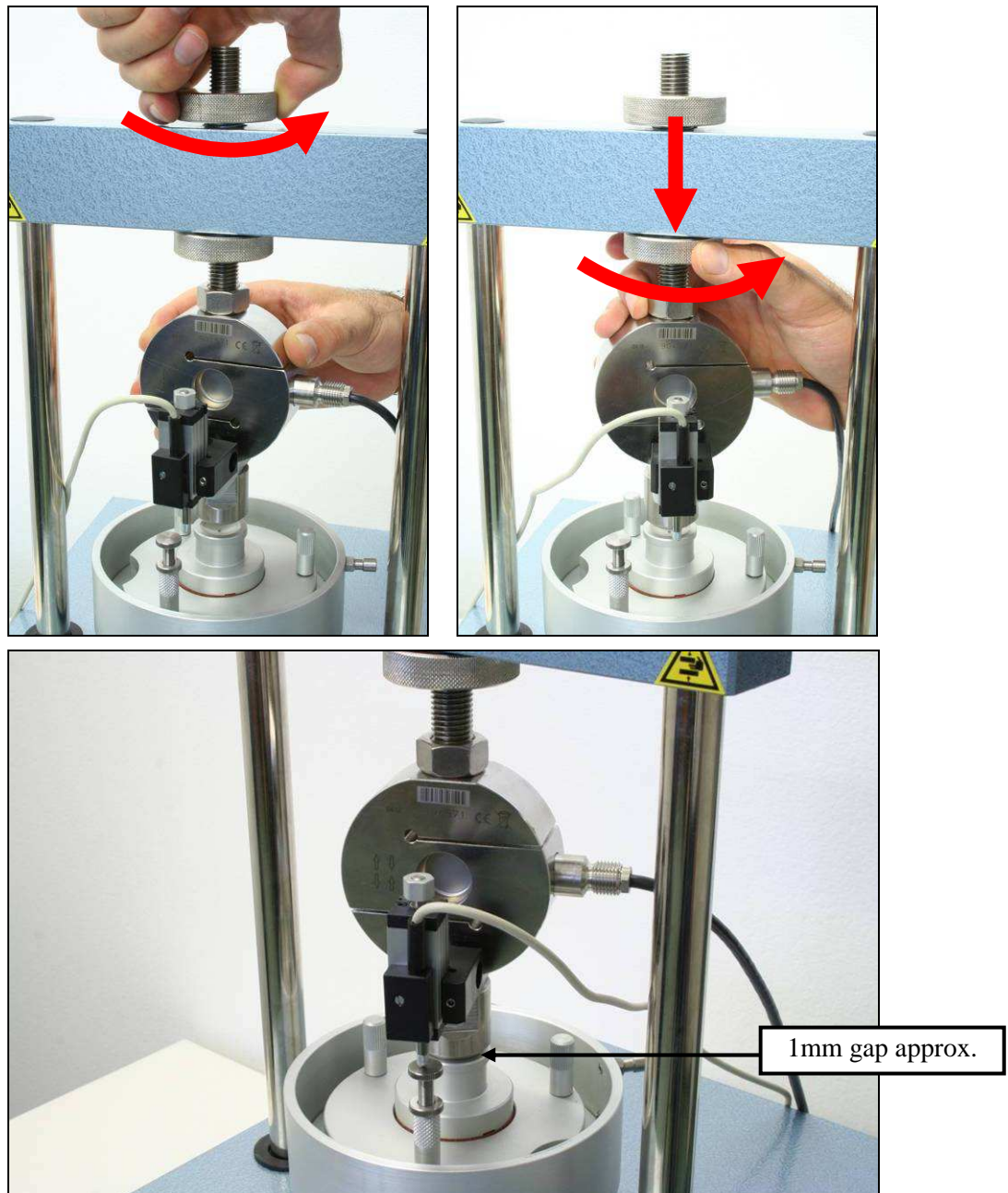

Fig. 4-47



NOTE:

Be careful not to damage the stem of the displacement transducer while performing these actions.

5. Position the displacement transducer in order the tip of its stem sets at approx. 1mm from the plate of the adjustable consolidation cell screw (loosen the grub screw of the displacement transducer holder to adjust its height);

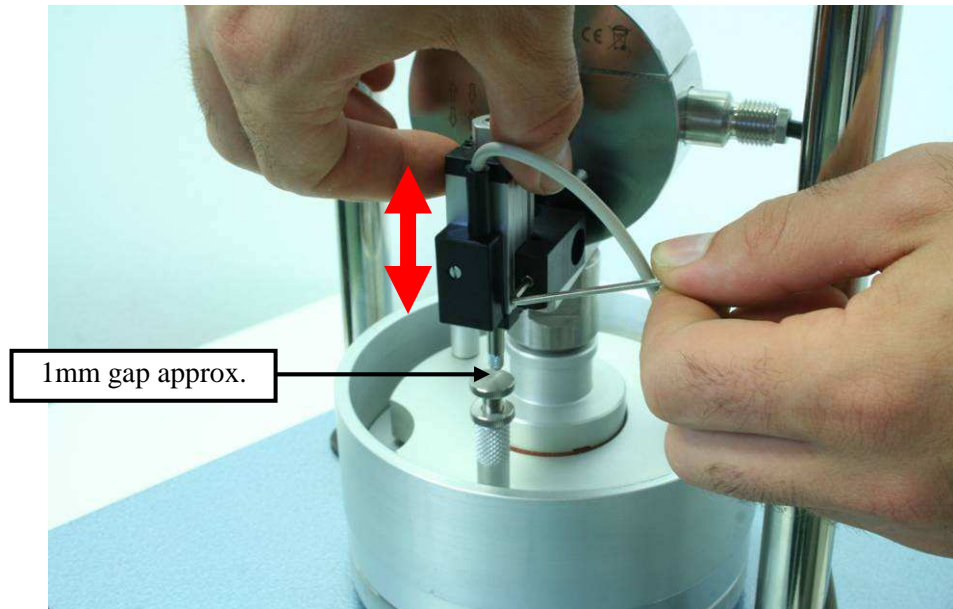

Fig. 4-48

6. With the **ACE EmS** unit turned-on and the display on, the **MAIN MENU** screen appears;
7. Choose between **OEDOMETER TEST** or **UNCONFINED TEST** (for **UNCONFINED TEST** don't use the consolidation cell but the relative accessories);



WARNING:

At the start of the preload phase, the loading rod of the loadcell will suddenly come in touch with of the top cap of the consolidation cell. Keep hands/fingers away from the area to avoid pinching (residual risk).

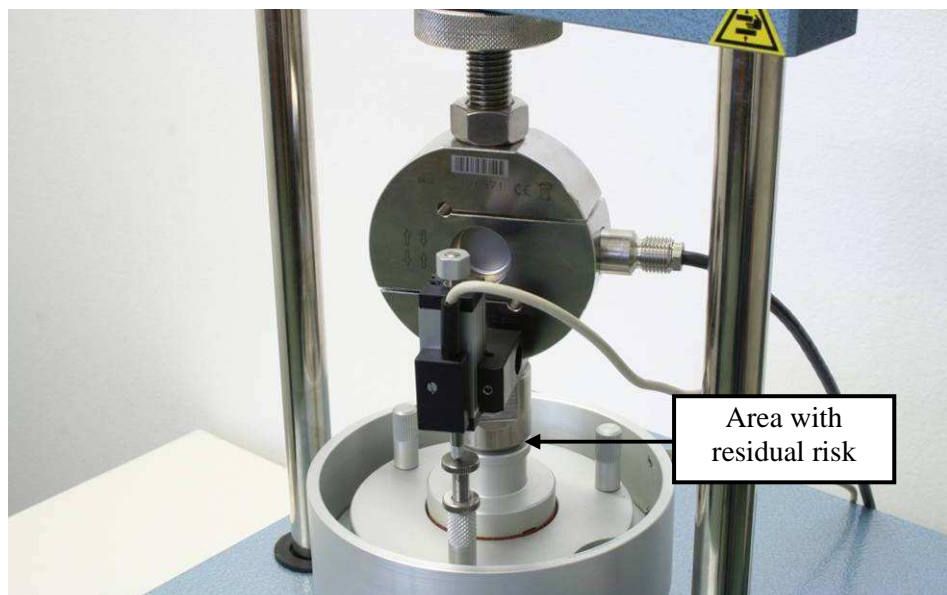

Fig. 4-49

8. Manually compress the displacement transducer of 1mm approx. and zero its reading;
9. Set all parameters before starting the test;
10. The following figures show: Oedometric Consolidation test screen and Unconfined test screen;
11. Press the **START** button;

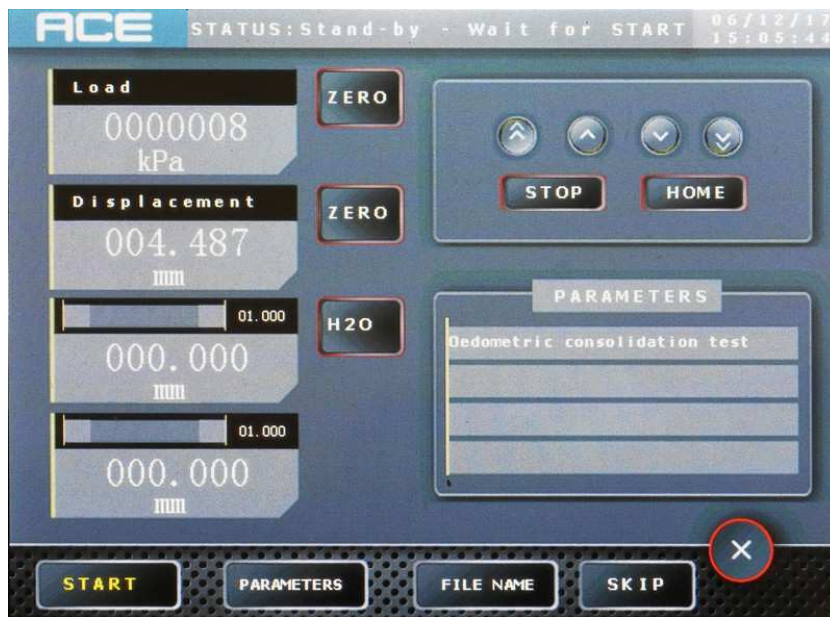

Fig. 4-50 (Oedometric Consolidation test screen)



Fig. 4-51 (Unconfined test screen)

The **GRAPH** screen on the display shows the data and the graph of the test currently running; it is possible to review different pages.

Ticking the desired format of the X axis scale below the graph, it is possible to select among **LINEAR**, **LOGARITMIC** and **SQUARE** scale.



NOTE:

After the test, the total time may not correspond to the sum of all partial times, this slight discrepancy is due to the truncation approximation of the measured times.

Press the **SKIP** button in case you want to proceed with the next step before the set time of the present step is elapsed.

You can also modify existing steps not yet carried out and/or add new steps to the existing ones by pressing the button;

12. At the end of the running test the load set into the last step of the sequence will be maintained;
13. At the end of the last step, press the **HOME** button to unload the loadcell (the unit will home the platen with the consolidation cell);



WARNING:

After pressing the **HOME** button at the end of the test, the loading plate of the oedometer will suddenly move down towards the upper surface of the case of the unit. Keep hands/fingers away from the area to avoid pinching (residual risk).

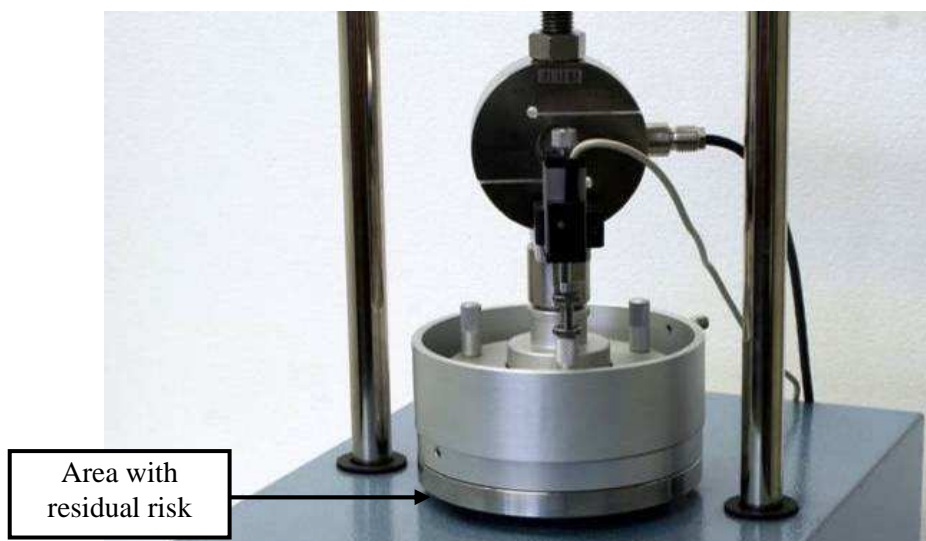

Fig. 4-52

14. Elaborate the data acquired.

4.6 Turning OFF the ACE EmS units

To turn-off the **ACE EmS** unit(s):

1. Make sure that the test has been completed and stopped (home position of the platen with the consolidation cell);



WARNING:

After pressing the **HOME button** at the end of the test, the loading plate of the oedometer will suddenly move down towards the upper surface of the case of the unit. Keep hands/fingers away from the area to avoid pinching (residual risk).

2. The **ACE EmS** unit can now be turned OFF via its mains switch on the rear panel;
3. Repeat the above procedure for all **ACE EmS** units of the system.

4.7 Removal of the sample and cleaning

To remove the sample and clean all parts of the consolidation cell (refer to next drawing):

1. Undo the 3 knurled screws of the consolidation cell;
2. Remove the top cap;
3. Remove the top plate;
4. Remove the upper porous disk and clean it by boiling in water;
5. Remove and discard the upper filter paper;
6. Remove the cutting ring with sample, weight it and put in an oven to dry it as required by the Standards;
7. Remove and discard the lower filter paper;
8. Remove the adapter;
9. Remove the lower porous disk and clean it by boiling in water;
10. Clean all parts from residual of the sample by using water.

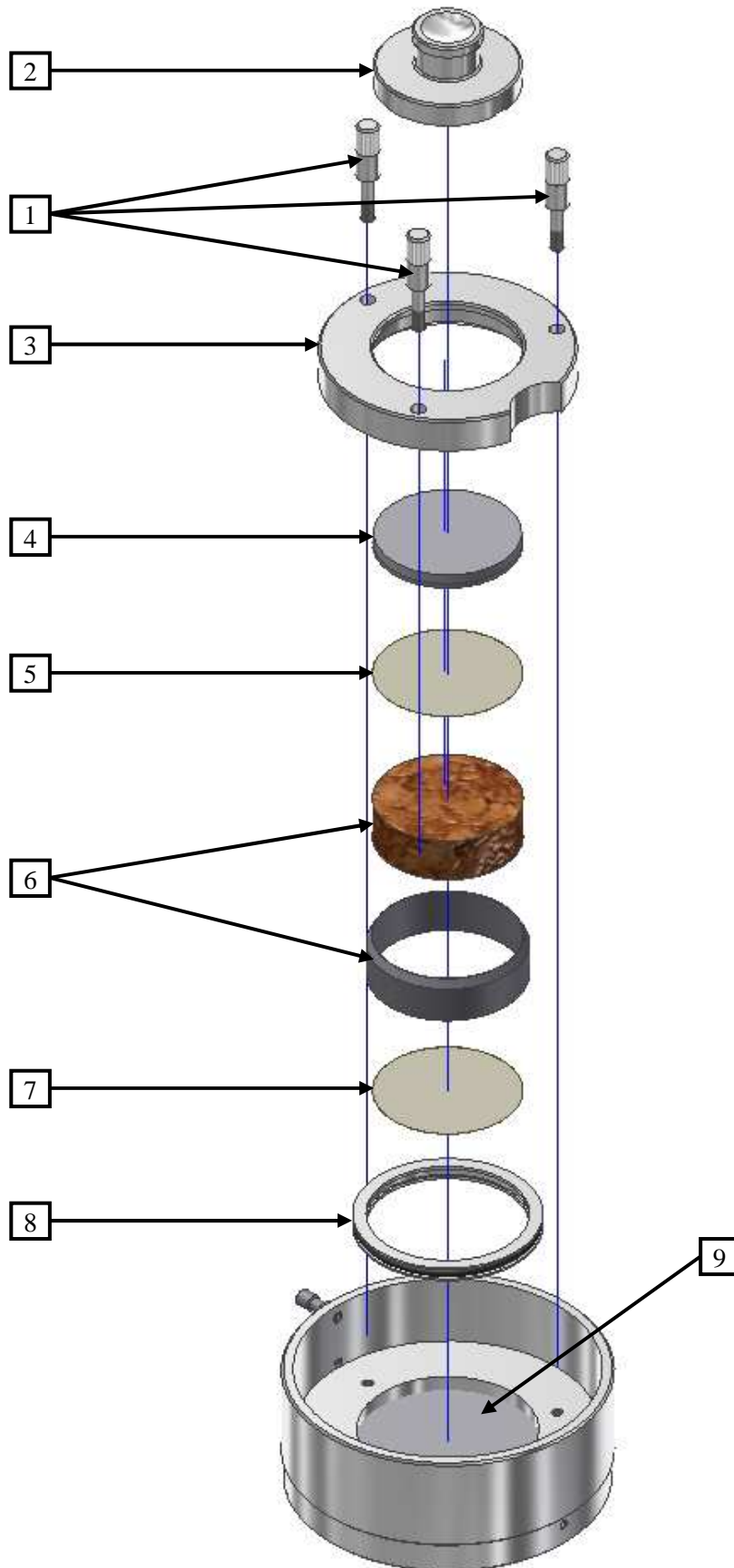

Fig. 4-53

5. MAINTENANCE

As with all electrical equipment, this unit must be used correctly and maintenance and inspections must be performed at regular intervals. Such precautions will guarantee the safe and efficient functioning of the equipment.

Periodic maintenance consists of inspections made directly by the test operator and/or by the authorized service personnel.

Maintenance to the equipment is responsibility of the purchaser and must be performed as stated by this chapter.

Failing to perform the recommended maintenance actions or maintenance performed by unauthorized people can void the warranty.



WARNING:

Failing to perform the recommended maintenance actions or maintenance performed by unauthorized people can void the warranty.

CONTROLS will not be responsible for maintenance and service actions performed by unauthorized people.



WARNING:

Before opening/removing the covers, disconnect the mains supply to the device and wait at least 5 minutes.



WARNING:

All safety devices must be functional at all time. Damaged protective covers or devices must be replaced immediately. When safety components are replaced, the protective devices are to be properly attached and tested. Any manipulation of the safety devices endangers the operating personnel.



WARNING:

Covers/doors can only be removed/opened by maintenance people, by using relevant tools/keys. These tools and keys are for the use of maintenance people only. Never leave them attached to the unit as this may endanger operator safety.

After performing maintenance/repair, make sure that all covers/doors are properly closed and locked.



WARNING:

For continued fire protection, replace fuses with same type and rating. Also, in case of failure, components may only be replaced by using original spare parts. It is in the responsibility of the purchaser to ensure that fire prevention policies are properly implemented according to the CE provisions.

5.1 Operator's preventive maintenance

The inspections made directly by the operator are the following:

Action	Who	When
Check to ensure that there is no external damage to the equipment, which could jeopardise the safety of use.	Operator	Before every working session
Cleaning of the consolidation cell (see chapter 4.7).	Operator	At the end of each test
General inspection.	Operator	Weekly
Check status and functioning of the operator's command and command lights.	Operator	Weekly
Check that all label and rating plates are intact and properly attached.	Operator	Weekly

5.2 Authorized service engineer maintenance actions

In addition to the maintenance actions performed by the operator, the performance of the equipment is checked and, if necessary corrected, during the maintenance activities performed by the authorized service engineer, in accordance with the indications provided in the present manual.

The following table lists the maintenance actions and the relevant timing:

Action	Who	When
Status of the internal and external cables wear and tear and fastenings.	Authorized service engineer	Yearly
Grounding of all the accessible conductive parts.	Authorized service engineer	Yearly
Checking of the displacement transducers and load cells calibration (see chapter 4.2.3).	Authorized service engineer	Yearly or according to the quality procedures of the laboratory

6. DIAGNOSTICS & TROUBLESHOOTING

The present chapter provides information on the diagnostic programs present in the system and on the troubleshooting of the most common problems.

Depending on the problem encountered, the troubleshooting is carried out by dividing the system into functional blocks.

**WARNING:**

Before opening/removing the covers, disconnect the mains supply to the device and wait at least 5 minutes.

**WARNING:**

Covers/doors can only be removed/opened by maintenance people, by using relevant tools/buttons. These tools and buttons are for the use of maintenance people only. Never leave them attached to the unit as this may endanger operator safety. After performing maintenance/repair, make sure that all covers/doors are properly closed and locked.

**WARNING:**

All safety devices must be functional at all times. Damaged protective covers or devices must be replaced immediately. When safety components are replaced, the protective devices are to be properly attached and tested. Any manipulation of the safety devices endangers the operating personnel.

**WARNING:**

Refer to qualified service organization authorized by CONTROLS to carry out the service maintenance actions described in the chapter “Diagnostic and Troubleshooting”. CONTROLS has not to be held responsible for damages to the equipment and/or injuries to personnel in case the above is not strictly followed.

6.1 By-passing overtravel microswitch

The unit is equipped with 2 overtravel microswitches to limit the upper and lower range of travel of the jack. This to prevent damages to the mechanical parts.

In case any of the 2 microswitches is triggered, it will cut power to the motor of the vertical travel thus preventing further movements. To recover manual working condition, hold **RESET** black button for 5 seconds and in the meantime drive manually the motor upward or downward with the **DOUBLE / SINGLE ARROWS** buttons on the display.



Fig. 6-1

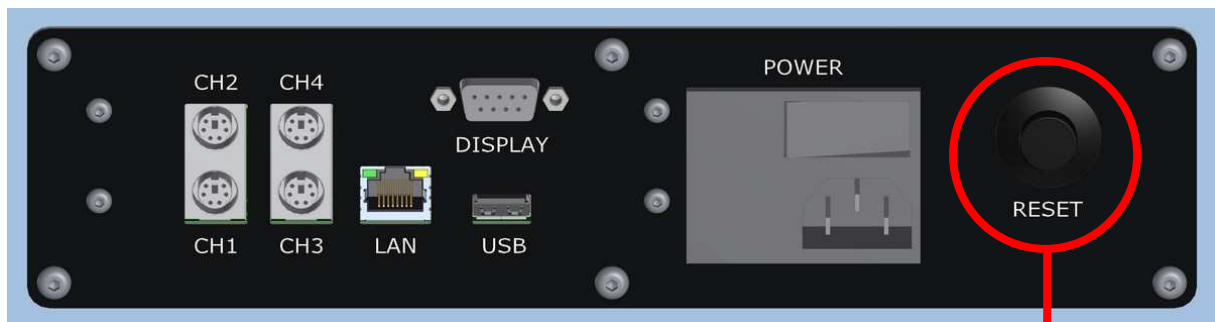

Fig. 6-2

RESET button

CONTROLS GROUP
CONTROLS S.p.A.
is certified **ISO 9001:2008**

CONTROLS Your Partners
Masters of Technology

controls-group.com

W^{ff} Wykeham Farrance Since 1941
PIONEERS IN ADVANCED SOL TESTING

wfi.co.uk

IPC global® | **CONTROLS GROUP**

ipcglobal.com.au